

DATASHEET

Type: **BIG ONE**
Name: Pendant light
ID: PC1335
Designed by: Lucie Koldová



Download

Description

In keeping with the brand's ongoing development of new technologies at the highest levels of quality and innovation, this year the Big One collection has received a technological upgrade in the form of a new LED panel that significantly increases the output of the lights. Enhanced metal components simplify handling. The outer glass features a gloss finish in the following colour options: transparent, smoke grey transparent, and a new smoke brown. The inner glass features a matte finish in the following colour options: triplex opal, smoke grey transparent, red transparent, light pink transparent, and a new smoke brown. The Big One collection is available in two sizes.



Tech. description

The Big One collection has undergone technological improvements in 2022 and 2023. The two halves of the glass core of the light are coupled by means of milled dural rings fitted with LED modules. The outer glass sphere is attached to the stainless-steel wire suspension ropes with a sophisticated mechanism that allows disassembly and reassembly by simply releasing the levers on top of the ring. The light is hung from a steel ceiling canopy, which also houses the electronics.

Colours options: https://brokis.sharepoint.com/:b:/s/brokis_sp/EbM5v6PQCHRLkHiuo9UPKc4BhALXNvBWrGLwBO-WcCmxEA

CONSTRUCTION SPECIFICATION

Weight: 6.5 kg
Construction material: glass, metal
Cord length [mm]: 2,200 mm
Mounting: Ceiling
Environment: Indoor

DIMENSIONS [mm]

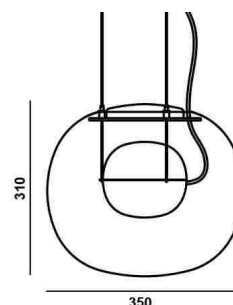

ELECTRICAL SPECIFICATION

Input voltage [V]: 100 - 240 V
Frequency [Hz]: 50-60 Hz
Max. power [W]: 15 W LED
Coverage IP: 20
Socket: LED module
Light source: -
Energy class: E

CERTIFICATIONS



BROKIS S.R.O.
ŠPANILOVA 1315/25
163 00 PRAHA 6 - ŘEPY
CZECH REPUBLIC

ORG ID 64940799
VAT ID CZ64940799
C 42174 MĚSTSKÝ SOUD
V PRAZE

TEL +420 567 211 517
TECHNICAL@BROKIS.CZ
INFO@BROKIS.CZ
WWW.BROKIS.CZ

2023_04
PAGE 1

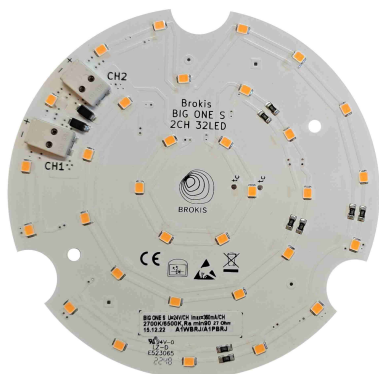

CM16711

Type	LED module
Lamp wattage [W]	7.5 W
Input voltage [V]	24 VDC
Energy class	E
Flux [lm]	947 lm
Light colour [K]	2700 K
CRI	90+
Dimmable	yes

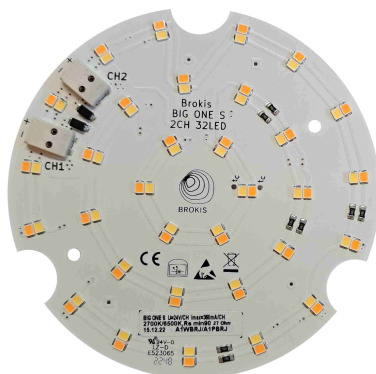

CM16293

Type	LED module
Lamp wattage [W]	7.5 W
Input voltage [V]	24 VDC
Energy class	E
Flux [lm]	947-1017 lm
Light colour [K]	2700-6500 K
CRI	90+
Dimmable	yes - tunable white



INNER FIXTURE

Dimensions O x w [mm] 210 x 60 mm
Weight [kg] 1.7 kg
Material metal

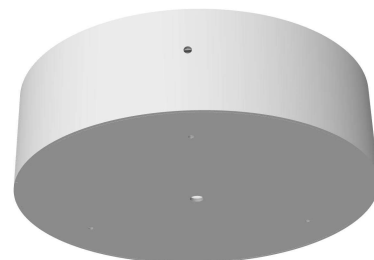

Drawing

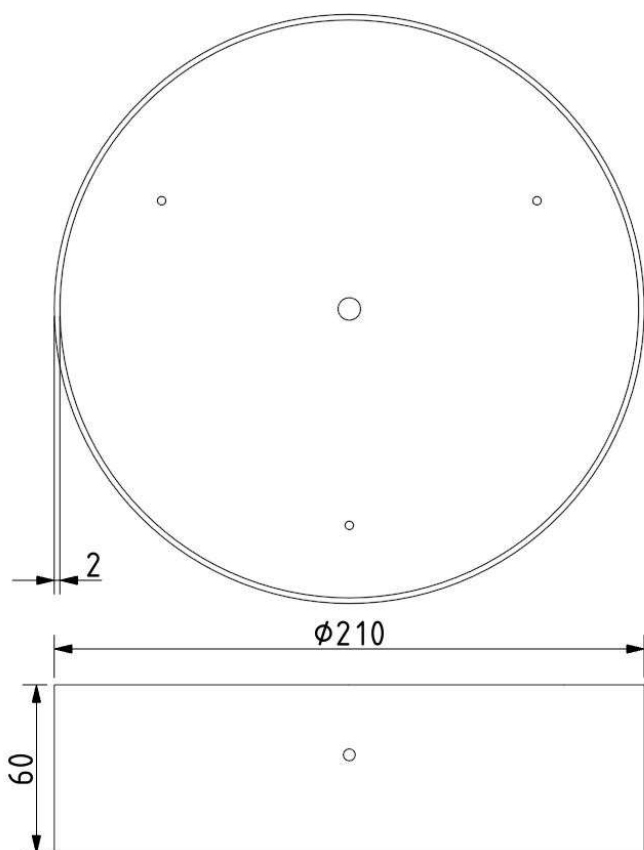

Hole placement

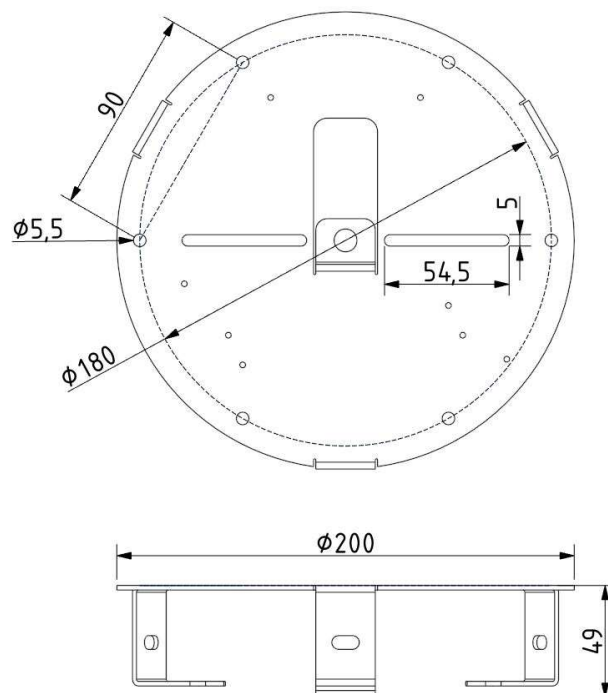

PRODUCT INFORMATION SHEET



Name BIG ONE SMALL

Type pendent lamp

ID PC1335



Description This large-format light with matte core by designer Lucie Koldova embodies a gentle poetry, simplicity, purity, and balanced proportions. A key role is played by the inoculation of luminous bodies and their mutual interaction in space – the light emitted from the smaller glass core flows freely through the atoms of air within the symbolic protective shell of the outer globe, while the sophisticated design of a bubble suspended in a large sphere evokes a sense of levitation. In keeping with the brand's ongoing development of new technologies at the highest levels of quality and innovation, this year the Big One collection has received a technological upgrade in the form of a new LED panel that significantly increases the output of the lights. Enhanced metal components simplify handling. The outer glass features a gloss finish in the following colour options: transparent, smoke grey transparent, and a new smoke brown. The inner glass features a matte finish in the following colour options: triplex opal, smoke grey transparent, red transparent, light pink transparent, and a new smoke brown. The Big One collection is available in two sizes.

Technical description The craftsmanship applied in production follows in the centuries-old tradition and experience of master glassmakers. The precision crafting of hand-blown glass instills distinctive, enduring character and outstanding quality in all BROKIS products. The glass shades are formed from multiple layers of molten glass, each of which is scrutinized by the master glassmaker prior to being blown into the mold. Up to 70% of the resulting quality is achieved in this stage of production.

Glass Colour

transparent glass	A	CGC23
smoke grey - transparent glass	A	CGC516
light smoke brown - transparent glass	A	CGC2889

Glass surface

glossy surface	A	CGSU66
----------------	---	--------

Inner glass colour

smoke grey - transparent glass	A	CGCI685
red - transparent glass	A	CGCI913
light pink - transparent glass	A	CGCI2356
triplex opal	A	CGCI907
smoke brown - transparent glass	A	CGCI2931

Inner glass finish

acid-etched both side surface	A	CGSUI905
-------------------------------	---	----------

Body finish

silver anodized	A	CCS775
-----------------	---	--------

Canopy finish

brushed stainless steel	A	CCSC974
-------------------------	---	---------

Cable colour

textile cable - black	A	CECL519
textile cable - white	A	CECL521
textile cable - light grey	A	CECL1918

LED Source

DIM, 24V, LED, 15W, 2700K, 1894lm, RA90+	A	LEDS2949
DIM (TW), 24V, LED, 15W, 2700K-6500K, 947lm-1017lm, RA90+	A	LEDS2950

Dimmable version

non-dimmable version	A	CEDV1457
DIM RF system - remote control version	A	CEDV1461
DIM PWM signal	A	CEDV1459
DIM 1-10V	A	CEDV1460
DIM DALI version	A	CEDV1458
DIM AC phase-cut	A	CEDV1730
DIM CASAMBI CBU-PWM4	A	CEDV2854
DIM (TW) CASAMBI CBU-PWM4	A	CEDV2942
DIM (TW) DALI version	A	CEDV2944