

DATASHEET

Type: **MEMORY**
Name: Ceiling light
ID: PC1333
Designed by: Boris Klimek & Lenka Dámová



Download

Description

The Memory collection awakens the imagination and beckons back to a carefree childhood. The wall and ceiling versions in different sizes, the wide range of color options, and a selection of finishes give this lighting experience a large degree of versatility.

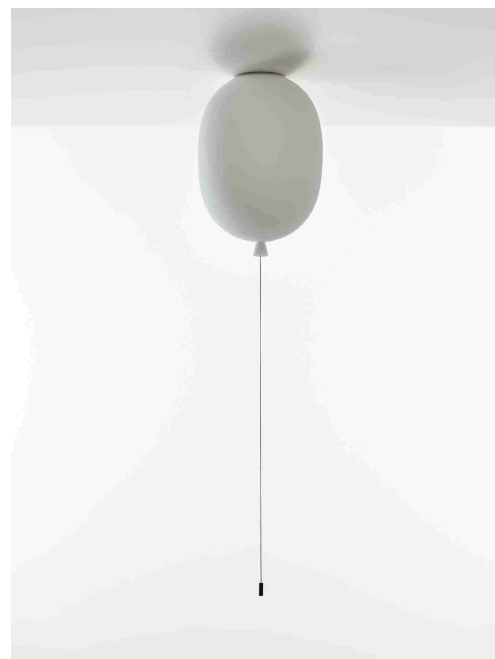

Tech. description

The light consists of a metal ceiling mount with E27 light source socket and a glass shade with bayonet system. The E27 socket has an integrated switch for manual control.

CONSTRUCTION SPECIFICATION

Weight: 2.5 kg
Construction material: glass, metal
Cord length [mm]: -
Mounting: Ceiling
Environment: Indoor

DIMENSIONS [mm]

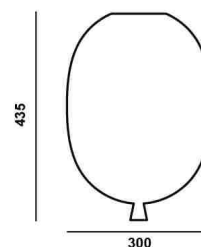

ELECTRICAL SPECIFICATION

Input voltage [V]: 230 V
Frequency [Hz]: 50-60 Hz
Max. power [W]: 60 W
Coverage IP: 20
Socket: E27
Light source: -
Energy class: A+ to E depending on light source

CERTIFICATIONS



BROKIS S.R.O.
ŠPANILOVA 1315/25
163 00 PRAHA 6 - ŘEPY
CZECH REPUBLIC

ORG ID 64940799
VAT ID CZ64940799
C 42174 MĚSTSKÝ SOUD
V PRAZE

TEL +420 567 211 517
TECHNICAL@BROKIS.CZ
INFO@BROKIS.CZ
WWW.BROKIS.CZ

2023_03
PAGE 1



INNER FIXTURE

Dimensions O x w [mm]	105 x 91.5 mm
Weight [kg]	0.2 kg
Material	metal



Drawing

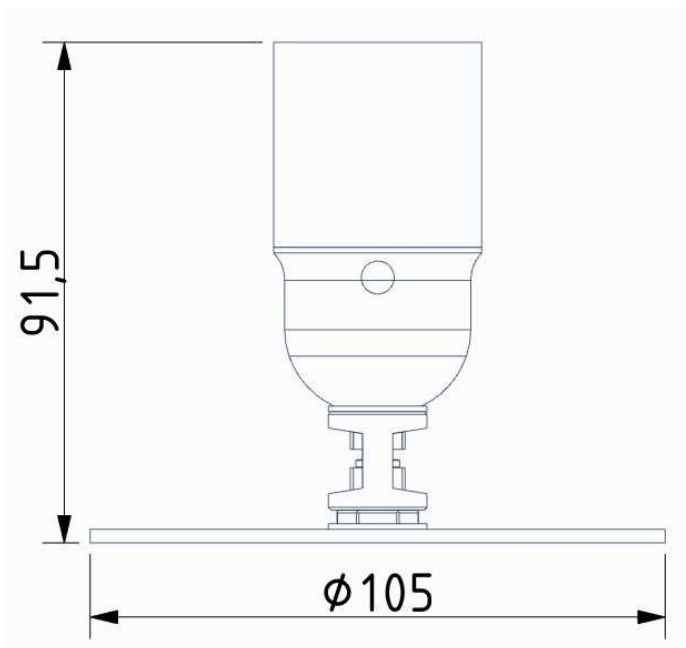

Hole placement

