

DATASHEET

Type: **PRISMA**
Name: Pendant light
ID: PC1311
Designed by: Lucie Koldová



Download

Description

The dominant feature of the Prisma collection is an extravagant metal fixture with a distinctive finish. Classic handblown glass spheres are anchored to either one or both ends of a robust decagonal metal prism that lends the collection its name. The shape in combination with the striking surface reflect light at different and unexpected angles, like a prism. With a choice of three different elegant finishes – brushed steel, galvanized yellow zinc gloss, or galvanized yellow zinc matte – the light is a bold artistic object in the interior offering unique vertical, horizontal, and diagonal compositions with subtle colourful reflections. The collection consists of a horizontal pendant light with two dual glass spheres and a vertical pendant light with a single glass sphere, both of which hang from wire ropes. Another typological variant is an impressive floor light, a majestic light sculpture in the form of a robust upright decagon topped with a luminous glass sphere.



Tech. description

The light comes in horizontal and vertical variants. The horizontal variant features dual LED modules with diffusers and glass shades. The vertical variant is fitted to the bottom of a metal fixture. The electronics are concealed within the ceiling canopy.

Colours options: https://brokis.sharepoint.com/:b/s/brokis_sp/EVThasyT8wJHt8UExud2dZoBFOQ1CIIRprozn-ALMy1cog

CONSTRUCTION SPECIFICATION

Weight: 3.9 kg
Construction material: glass, metal
Cord length [mm]: 2,200 mm
Mounting: Ceiling
Environment: Indoor

DIMENSIONS [mm]



ELECTRICAL SPECIFICATION

Input voltage [V]: 100 - 240 V
Frequency [Hz]: 50-60 Hz
Max. power [W]: 6 W
Coverage IP: 20
Socket: LED module
Light source: -
Energy class: E

CERTIFICATIONS



BROKIS S.R.O.
ŠPANILOVA 1315/25
163 00 PRAHA 6 - ŘEPY
CZECH REPUBLIC

ORG ID 64940799
VAT ID CZ64940799
C 42174 MĚSTSKÝ SOUD
V PRAZE

TEL +420 567 211 517
TECHNICAL@BROKIS.CZ
INFO@BROKIS.CZ
WWW.BROKIS.CZ

2022_10
PAGE 1

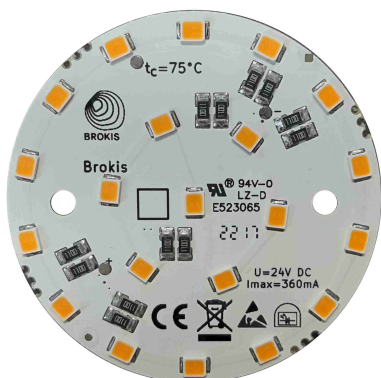

CM15124

Type	LED module
Lamp wattage [W]	6 W
Input voltage [V]	24 VDC
Energy class	E
Flux [lm]	683 lm
Light colour [K]	2700 K
CRI	90+
Dimmable	yes



INNER FIXTURE

Dimensions O x w [mm] 129 x 70 mm
Weight [kg] 1 kg
Material metal

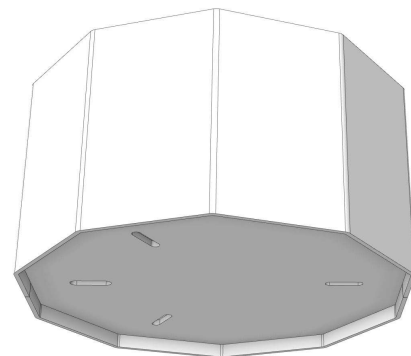

Drawing

Hole placement

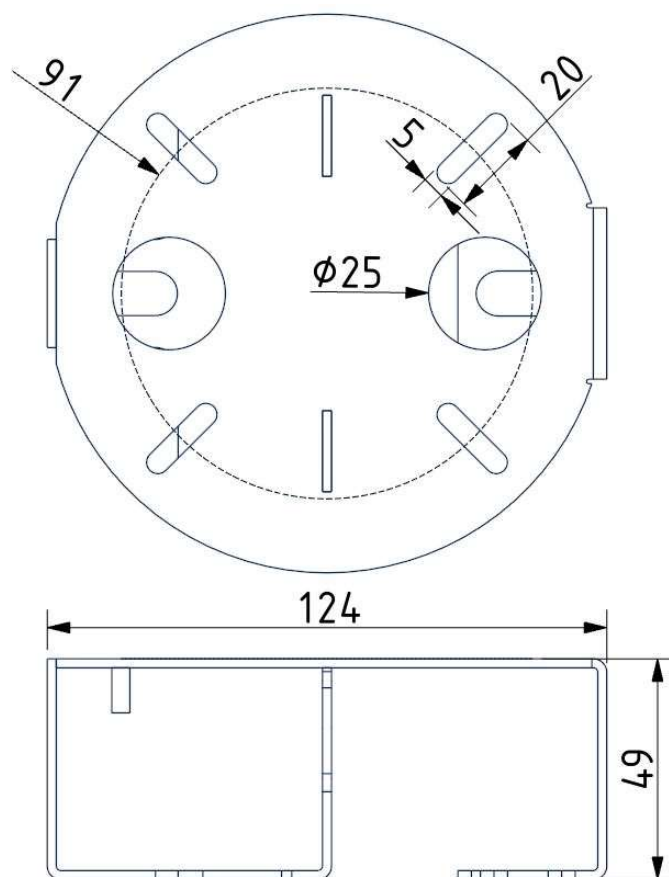
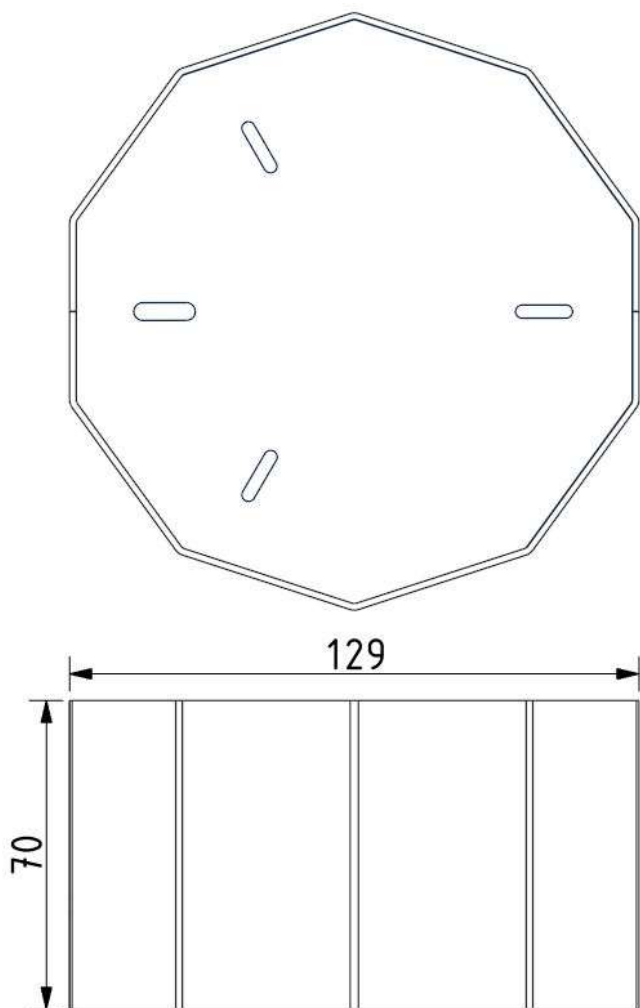

PRODUCT INFORMATION SHEET



Name PRISMA PENDENT SINGLE SMALL 350

Type pendent lamp

ID PC1311



Description The dominant feature of the Prisma collection is an extravagant metal fixture with a distinctive finish. Classic handblown glass spheres are anchored to either one or both ends of a robust decagonal metal prism that lends the collection its name. The shape in combination with the striking surface reflect light at different and unexpected angles, like a prism. With a choice of two different elegant finishes – brushed steel or yellow zinc lacquer – the light is a bold artistic object in the interior offering unique vertical, horizontal, and diagonal compositions with subtle colourful reflections. The collection consists of a horizontal pendent light with two dual glass spheres and a vertical pendent light with a single glass sphere, both of which hang from wire ropes. Another typological variant is an impressive floor light, a majestic light sculpture in the form of a robust upright decagon topped with a luminous glass sphere. The structured finish on the metal fixture is one of the defining traits of the collection, and together with transparent glass or grey smoke glass constitutes a jewel with which to adorn private interiors as well as hotels and restaurants.

Technical description The technologies applied in production follow in the centuries-old tradition and experience of master glassmakers. The precision crafting of handblown glass instils distinctive, enduring character and outstanding quality in all BROKIS products. The glass lampshades are formed from multiple layers of molten glass, each of which is scrutinized by the master glassmaker prior to being blown into the mould. The metal parts are made of high-grade steel plate. The zinc finishes are galvanized, which creates a textured surface, one of the defining features of the collection. The subtle, almost invisible welds are a testament to the superior craftsmanship of BROKIS lights.

Glass Colour

transparent glass	A	CGC23
smoke grey - transparent glass	A	CGC516

Glass surface

glossy surface	A	CGSU66
----------------	---	--------

Body finish

Yellow zinc lacquer	A	CCS2964
Brushed steel lacquered	A	CCS2887

Canopy finish

Yellow zinc lacquer	A	CCSC2965
Brushed steel lacquered	A	CCSC2888

Cable colour

coaxial cable - silver	A	CECL2772
------------------------	---	----------

LED Source

24V, LED, 6W, 2700K, 683lm, RA90, DIM	A	LEDS2901
---------------------------------------	---	----------

Dimmable version

non-dimmable version	A	CEDV1457
DIM RF system - remote control version	A	CEDV1461
DIM PWM signal	A	CEDV1459
DIM 1-10V	A	CEDV1460
DIM DALI version	A	CEDV1458
DIM AC phase-cut	A	CEDV1730
DIM CASAMBI CBU-PWM4	A	CEDV2854