



## Description

The combination of handblown glass, handcrafted wood, and classic shaping has given rise to a light of ageless elegance. The collection comprises four different suspension lights, as striking alone as they are in sets, characterized by a handblown glass shade set upon on a handcrafted wooden body.



**Tech. description** The light consists of five wooden bodies with connectors and GZ10 light source sockets. It also includes lead cables with connectors (compatible with GZ10 and GU10 light sources), the glass shades, and a metal ceiling canopy.

Colours options: [https://brokis.sharepoint.com/:b:/s/brokis\\_sp/EZSYV9QBSpEtbnJ\\_W2dpEBrs4exUsKy7\\_LGA2V3MAE](https://brokis.sharepoint.com/:b:/s/brokis_sp/EZSYV9QBSpEtbnJ_W2dpEBrs4exUsKy7_LGA2V3MAE)

## CONSTRUCTION SPECIFICATION

<b>Weight:</b>	8,5kg
<b>Construction material:</b>	glass, wood, metal
<b>Cord length [mm]:</b>	2,000 mm
<b>Mounting:</b>	Ceiling
<b>Environment:</b>	Indoor

## DIMENSIONS [mm]

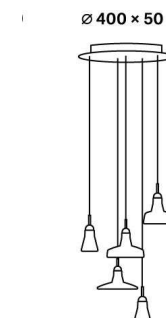

## ELECTRICAL SPECIFICATION

<b>Input voltage [V]:</b>	230 V
<b>Frequency [Hz]:</b>	50-60 Hz
<b>Max. power [W]:</b>	5 x 5 W
<b>Coverage IP:</b>	20
<b>Socket:</b>	5 x GZ10
<b>Light source:</b>	-
<b>Energy class:</b>	A+ to B depending on light source

## CERTIFICATIONS





### CM2409 LAMPIA GU10-60°

<b>Socket</b>	GU10
<b>Type</b>	LED
<b>Lamp wattage [W]</b>	5 W
<b>Input voltage [V]</b>	220 - 240 VAC
<b>Energy class</b>	A+
<b>Flux [lm]</b>	336 lm
<b>Light colour [K]</b>	2700 K
<b>CRI</b>	90+
<b>Lifespan [h]</b>	25000h
<b>Dimmable</b>	yes
<b>Dimensions h x w [mm]</b>	55 x 50 mm

# DATASHEET

## RECOMENDED CANOPY



Download

### CEILING CANOPY

Dimensions O x w [mm]	400 x 52 mm
Weight [kg]	3,2 kg
Material	metal

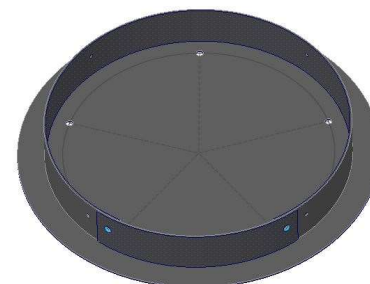

### Drawing

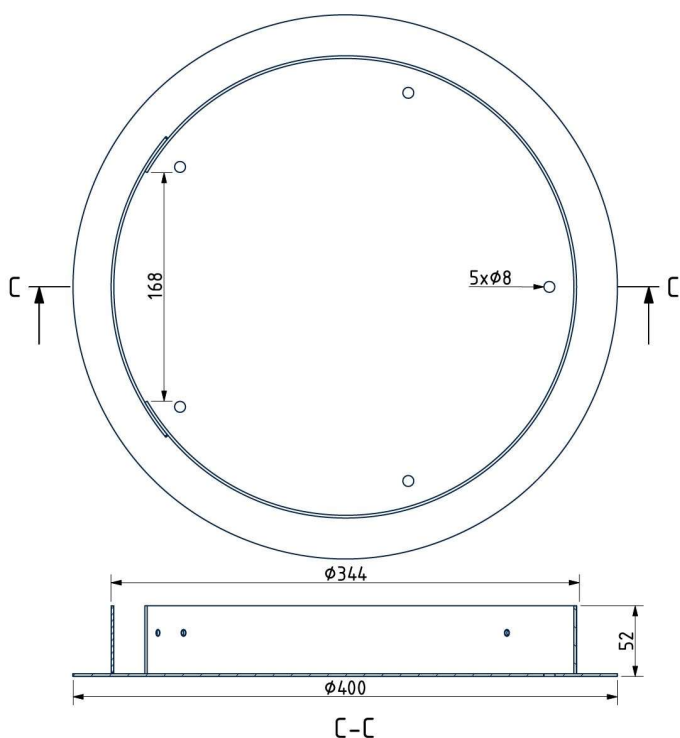

### Canopy bracket

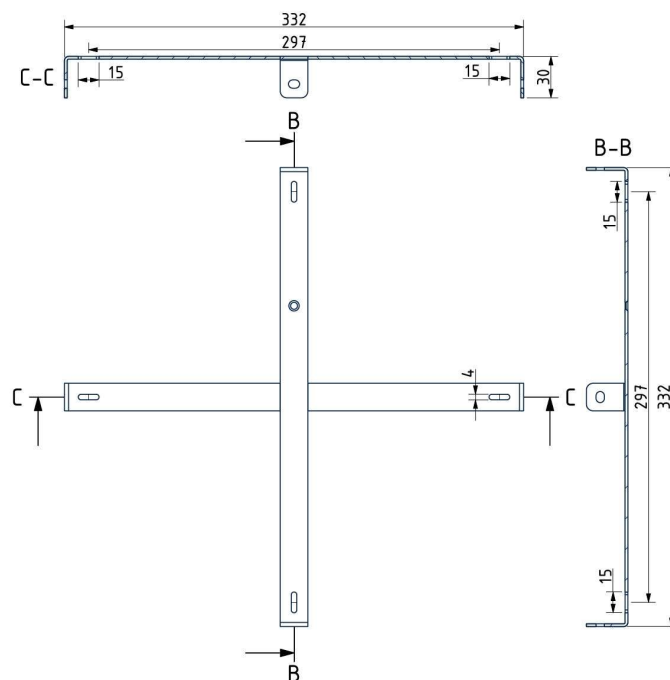

# PRODUCT LIST

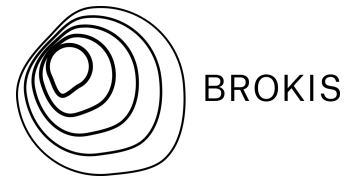

BROKIS

**Name** SHADOWS SET RING CANOPY

**Type** pendent lamp

**ID** PC929



**Description** The Shadows collection is a take on the famed, timeless lights found in French ateliers, and its typology pays tribute to that legacy. The combination of handblown glass, handcrafted wood, and classic shaping has given rise to a light of ageless elegance. The collection comprises four different suspension lights, as striking alone as they are in sets, characterized by a handblown glass shade set upon on a handcrafted wooden body. The clean contours and finish are accentuated by the concealed light source. The Shadows collection is special not only for its wide spectrum of glass colour options, surface finishes, and types of wood but also because the lights can be combined into sets according to customer requirements. They are intended for interiors and, thanks to multiple combination possibilities, are well suited to a broad range of installations. Shadows have special integrated connectors developed by Brokis to facilitate installation and cleaning.

**Technical description** The craftsmanship applied in production follows in the centuries-old tradition and experience of master glassmakers. The precision crafting of hand-blown glass instills distinctive, enduring character and outstanding quality in all Brokis products. The glass shades are formed from multiple layers of molten glass, each of which is scrutinized by the master glassmaker prior to being blown into the mold. Up to 70% of the resulting quality is achieved in this stage of production. No less attention to detail is paid in handcrafting the wooden elements of the light. Each piece is individually processed by the artisan in a series of strictly observed production stages. We take special care in selecting quality fine wood and ecologically friendly materials to treat it with.

## **Glass Colour**

transparent glass	A	CGC23
smoke grey - transparent glass	A	CGC516
smoke brown - transparent glass	A	CGC538
opaline - transparent glass	A	CGC38
triplex opal	A	CGC39
black - transparent glass	A	CGC602
pearl grey - opaline glass	A	CGC1916

## **Glass surface**

glossy surface	ALL	CGSU66
acid-etched outside surface	ALL	CGSU67

## **Body finish**

European oak - untreated	A	CCS657
European oak - clear coat	A	CCS972
European oak - natural waxed	A	CCS518
European oak - stained black	A	CCS592
European oak - stained white	A	CCS680
American walnut - natural waxed	B	CCS757

## **Canopy finish**

iron - black matte powder coating	A	CCSC619
iron - white matte powder coating	A	CCSC618

## **Connection method**

BROKIS connector	A	CCM1019
------------------	---	---------

### **Cable colour**

textile cable - black	A	CECL519
textile cable - white	A	CECL521
textile cable - dark grey	A	CECL520
textile cable - light grey	A	CECL1918
textile cable - red	A	CECL530
textile cable - yellow	A	CECL606

### **Recommended Bulbs**

230V, GU10, 5W, 2700K, 336lm, RA90, 60°, DIM	A	CEB373
--	---	--------