



EVITA

AQUILIALBERG / 2011

EN Dimmable floor lamp. Composite body structure of multilayered steel and technopolymers, thermo extensible fabric diffuser.

IT Lampada da terra dimmerabile. Struttura composta in multistrato accoppiato di acciaio e tecnopolimeri, diffusore in telo termoteso.

CERTIFICATIONS / CERTIFICAZIONI



Product in class I
Apparecchio di classe I

IP20

Product for indoor use
Apparecchio per uso interno



Product in conformity with the European directive 2006/95/EC
Apparecchio conforme alla direttiva europea 2006/95/EC



Product in conformity with the Eurasian Custom Unions technical regulations
Apparecchio conforme ai regolamenti tecnici dell'Unione doganale Eurasiatca



This lamp must be disposed in conformity with the EU directive 2002/96/EC
Apparecchio di illuminazione da smaltire secondo la direttiva EU 2002/96/EC

CODES AND DIMENSIONS / CODICI E DIMENSIONI

K155060B
K155060N
K155060T
K155060R

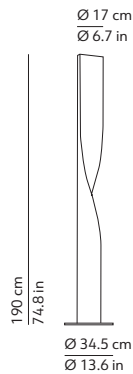

PACKAGING / IMBALLO

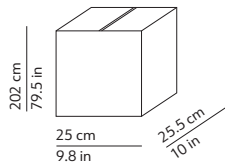

Structure
Volume: 0.129 m³ / 4.548 ft³
Gross weight: 12.54 kg / 27.59 lbs

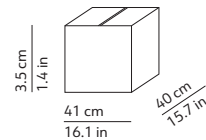

Base
Volume: 0.006 m³ / 0.203 ft³
Gross weight: 6.32 kg / 13.90 lbs

MATERIALS AND FINISHINGS / MATERIALI E FINITURE

STRUCTURE / STRUTTURA

○ Warm white / Bianco
RAL 1013
Shiny / Lucido

● Black / Nero
RAL 9005
Shiny / Lucido

● Dove-grey / Tortora
RAL 7006
Shiny / Lucido

● Red / Rosso
RAL 3003
Shiny / Lucido



Steel and technopolymers diffuser
Diffusore in acciaio e tecnopolimeri

Metalic base
Base in metallo

DIFFUSER / DIFFUSORE

○ White / Bianco
Shiny / Lucido

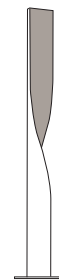



Thermo extensible fabric
Telo termoteso

FURTHER INFORMATION / INFORMAZIONI AGGIUNTIVE

 230V
or 120V Feeding / Alimentazione

Light source / Sorgente luminosa
2 x 54W - T5
fluorescent or compatible LED light source
fluorescente o sorgente led compatibile

 Energy efficiency class A+

 Dimmer / Varialuce
Yes

 Floor lamp
Lampada da terra

 Transparent cord set
EU, USA or UK plug
Cavo di alimentazione trasparente
Spina EU, USA o UK

 Electronic loose dimmer 0/100% - transparent
Varialuce rompifilo elettronico 0/100% - trasparente

ASSEMBLY INSTRUCTIONS
ISTRUZIONI DI MONTAGGIO
INSTRUCCIONES DE MONTAGE
MONTAGE-ANLEITUNG
INSTRUCCIONES DE MONTAJE
ИНСТРУКЦИИ ПО МОНТАЖУ

EVITA

AQUILIALBERG

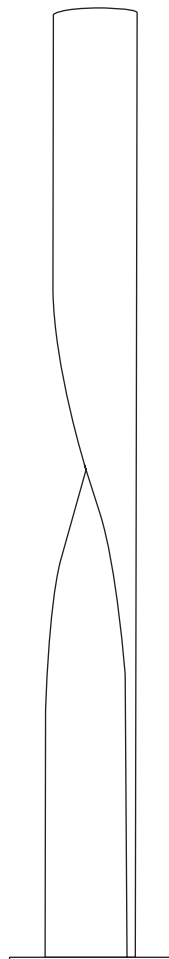

WARNING

The safety is guaranteed by the appropriate use of the following instructions, so you must keep them. Always disconnect the main voltage before working on the appliance.
Never use abrasive products or aggressive detergents for cleaning the lamp.
If the external cable of this appliance is damaged, it must be replaced by the manufacturer, its after sales service or other equivalent qualified person only in order to avoid any danger. Kundalini will not provide a replacement until the nature of defect has been determined.

ATTENZIONE

La sicurezza dell'apparecchio è garantita con l'uso appropriato delle seguenti istruzioni, pertanto è necessario conservarle. Togliere sempre la tensione prima di operare sull'apparecchio.
Per pulire la lampada non usare mai prodotti abrasivi o detersivi aggressivi.
Se il cavo esterno di questo apparecchio viene danneggiato, deve essere sostituito esclusivamente dal costruttore, dal suo servizio assistenza, o da personale qualificato equivalente, al fine di evitare pericoli. Kundalini non effettuerà nessuna sostituzione se non dopo aver accertato la natura del difetto.

ATTENTION

La sûreté de l'appareil n'est garantie qu'en suivant scrupuleusement les instructions ci-après. Il est donc nécessaire de les conserver.
Isoler l'appareil du secteur avant toute manipulation.
Pour nettoyer la lampe, ne jamais utiliser de produits abrasifs ou de nettoyeurs agressifs.
Si le câble externe de cet appareil est endommagé, il doit être remplacé uniquement par les soins du constructeur, par son service après-vente ou bien par le personnel équivalent, et ce afin d'éviter tout danger. Kundalini ne remplacera aucun appareil sans en avoir pu vérifier le défaut.

ACHTUNG

Die Sicherheit dieses Artikels wird nur durch die strikte Befolgung der nachfolgenden Betriebsanleitung gewährleistet. Bitte heben Sie diese unbedingt auf.
Vor allen Arbeiten ziehen Sie bitte den Stecker aus der Dose.
Für die Reinigung der Lampe niemals Schleifmittel oder aggressive Reinigungsmittel verwenden
Sollte das Außenkabel der Lampe beschädigt werden, ist es ausschließlich vom Service-Dienst des Herstellers oder gleichwertigen, qualifiziertem Personal auszutauschen, um somit Gefahren zu vermeiden.
Kundalini leistet grundsätzlich erst nach einer gründlichen Überprüfung Ersatz.

ATENCIÓN

La seguridad del aparato está garantizada sólo con el uso apropiado de las instrucciones siguientes, por lo tanto es necesario atenderlas puntualmente.
Desconectar siempre la alimentación antes de trabajar en el aparato.
Nunca utilice productos abrasivos o detergentes agresivos para limpiar la lámpara.
Si el cable externo de este aparato se deteriora será necesario sustituirlo; la sustitución podrá efectuarla exclusivamente el fabricante, su servicio de asistencia o personal cualificado equivalente para evitar peligros.
Kundalini no efectuará sustitución alguna hasta después de haber verificado la naturaleza del defecto.

ВНИМАНИЕ!

Безопасность прибора обеспечивается за счет правильного пользования настоящими инструкциями, поэтому необходимо их сохранять.
Перед началом работы на приборе всегда отключать напряжение.
Для очистки лампы не использовать абразивные продукты или агрессивные чистящие средства.
Если внешний кабель прибора поврежден, во избежание опасностей он должен быть заменен только изготовителем, его сервисной службой или равнозначным квалифицированным персоналом.
Kundalini не выполняет никаких замен, если не было установлено происхождение дефекта.

EVITA



EVITA Led



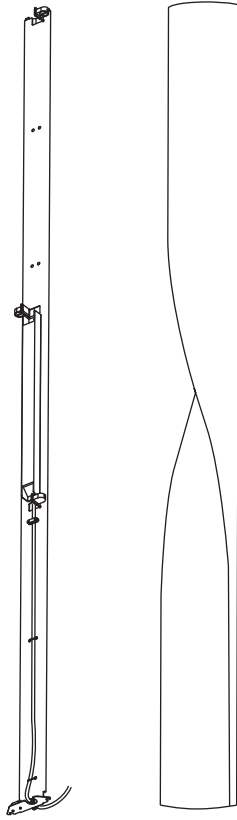

BOX N.1

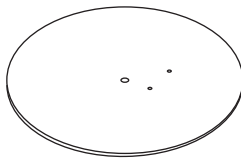

BOX N.2

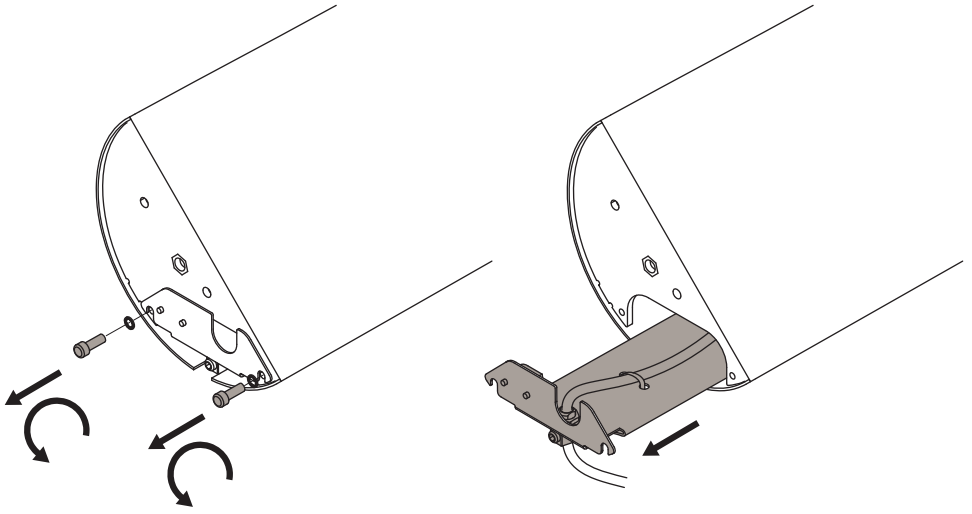

.1 EVITA

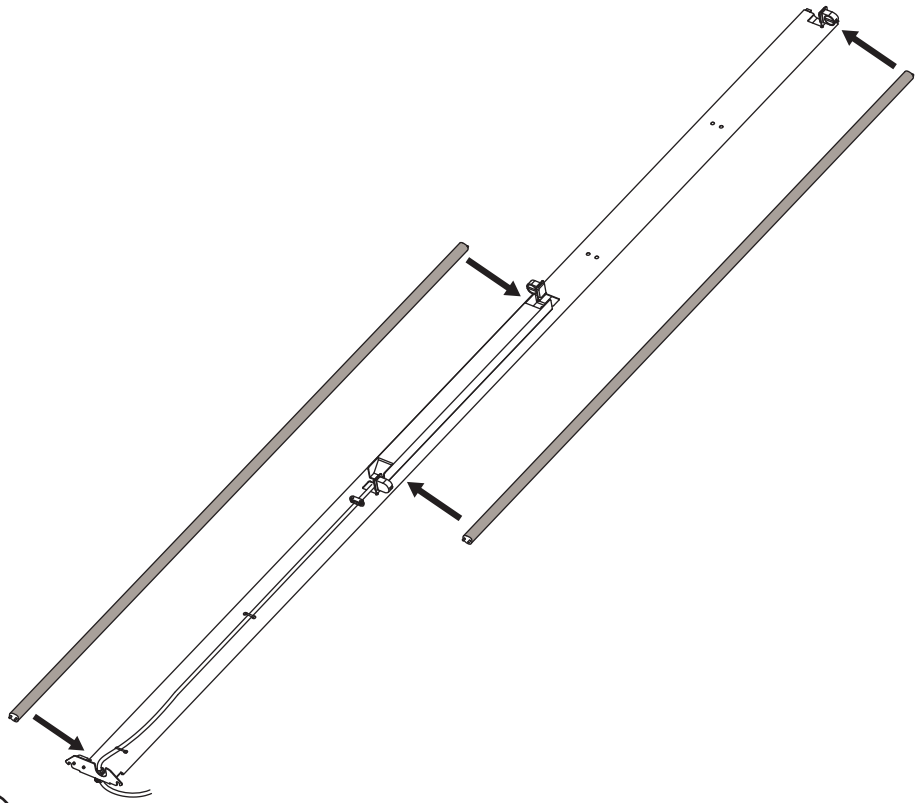

.2 EVITA

.3

EVITA

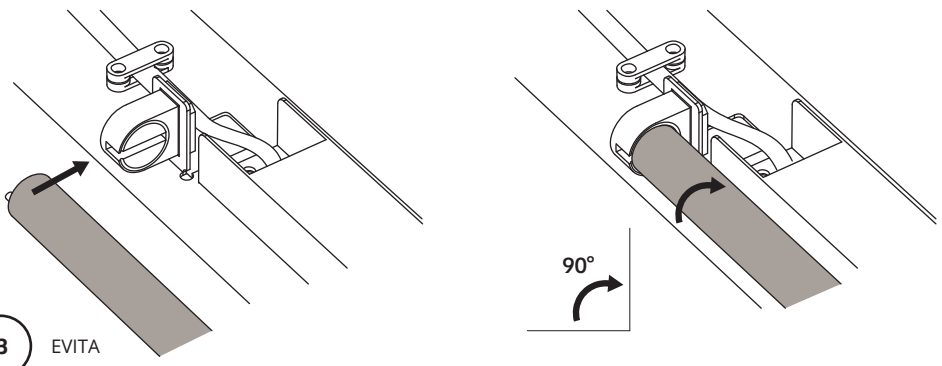

.4

EVITA

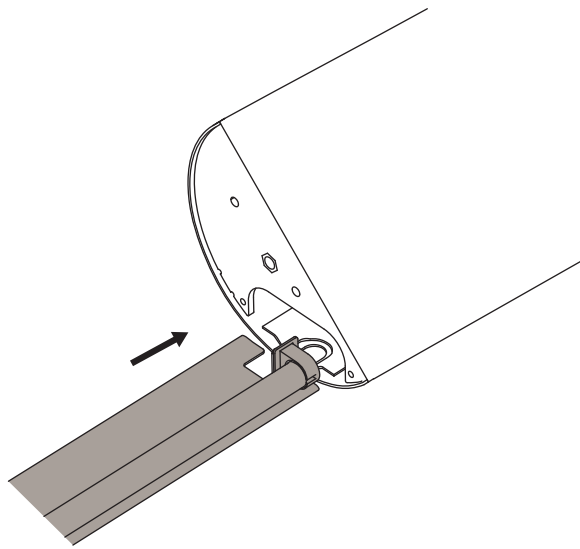

.5

EVITA + EVITA Led

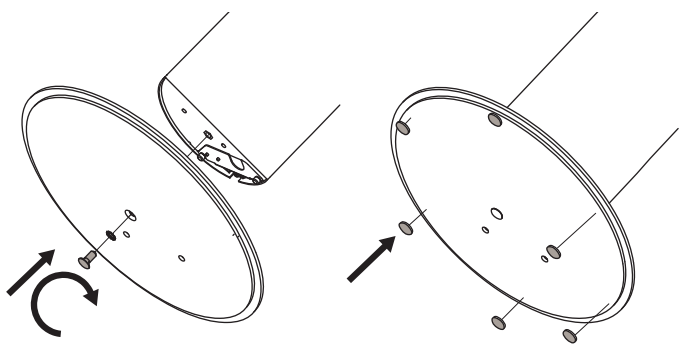

ISTRUZIONI DI MONTAGGIO

Funzionamento del dimmer

Il comando di dimmerazione della lampada coincide con l'interruttore presente sul cavo di alimentazione. Una pressione rapida comanderà accensione e spegnimento, una pressione prolungata controlla la dimmerazione, l'elettronica memorizza l'ultima operazione effettuata abbinando alternatamente alla pressione dell'interruttore la diminuzione o l'aumento della luce.

ASSEMBLY INSTRUCTIONS

Dimmer

The dimming of the lamp is activated using the on/off button on the feeding cable. One quick, full pressure, click will turn the lamp on/off, a prolonged pressure controls the dimming effect. The electronic components will memorize the last operation and will alternately match the increase or decrease of the light's intensity with every click.

MONTAGE-ANLEITUNG

Dimmer

Die Steuerung des Dimmers der Lampe erfolgt über den Schalter am Versorgungskabel. Ein kurzer Druck schaltet die Lampe an und aus, ein längerer Druck steuert den Dimmer; die Elektronik speichert den letzten Vorgang und löst bei Drücken des Schalters abwechselnd Dimmen oder Erhöhung der Helligkeit aus.

INSTRUCTIONS DE MONTAGE

Variateur d'intensité

La commande de variation de la luminosité de la lampe coïncide avec l'interrupteur présent sur le cordon d'alimentation. Une brève pression pour allumer et éteindre. Une longue pression pour augmenter ou diminuer l'intensité lumineuse. Pour une nouvelle commande d'allumage, de réglage ou d'extinction, relâcher le bouton et donner de nouveau la commande désirée. Le système électronique mémorise le niveau de variation au moment de l'extinction.

INSTRUCCIONES DE MONTAJE

Regulador

El botón para regular la intensidad de la luz de la lámpara coincide con el interruptor que está en el cable de alimentación. Una rápida presión ordenará el encendido y el apagado, una presión prolongada controla la regulación de la intensidad de la luz; la electrónica memoriza la última operación realizada uniendo alternativamente a la presión del interruptor la disminución o el aumento de la luz.

ИНСТРУКЦИИ ПО МОНТАЖУ

Работа регулятора света

Управление яркостью света лампы совмещено с переключателем на кабеле питания. Быстрое нажатие включает и выключает, длительное нажатие управляет яркостью; электроника запоминает последнюю выполненную операцию, поочередно комбинируя уменьшение или увеличение освещенности с нажатием переключателя.

BULBS, LAMPADINE, AMPOULES, LEUCHTENMITTEL, BOMBILLAS, ТИП ЛАМПОЧКИ

EVITA

2 x 54W - T5

Energy efficiency class A+

EVITA Led

Board LED 4 x 15W - 2700 K - 6000 lm

Energy efficiency class A+

FEEDING, ALIMENTAZIONE, ALIMENTATION, SPANNUNG, TENSION DE RED, НАПРЯЖЕНИЕ

EVITA

220-240 / 120 V

EVITA Led

220-240 V

