

KUSHI XL table

ALBERTO SAGGIA & VALERIO SOMMELLA / 2019

^{EN} Table lamp. Opal diffuser made of two layers of mouth blown glass. Metallic body available in three coating finishes: black, copper and brass.

^{IT} Lampada da tavolo. Diffusore in vetro opale incamiciato e soffiato. Struttura in metallo verniciato in tre versioni: nero, rame e ottone.



CERTIFICATIONS / CERTIFICAZIONI



Product in class II
Apparecchio di classe II

IP20

Product for indoor use
Apparecchio per uso interno



Product in conformity with the European directive 2006/95/EC
Apparecchio conforme alla direttiva europea 2006/95/EC



Product in conformity with the Eurasian Custom Unions technical regulations
Apparecchio conforme ai regolamenti tecnici dell'Unione doganale Eurasiatca



USA and Canada conformity seal
Marchio di conformità USA e Canada



This lamp must be disposed in conformity with the EU directive 2002/96/EC
Apparecchio di illuminazione da smaltire secondo la direttiva EU 2002/96/EC

CODES AND DIMENSIONS / CODICI E DIMENSIONI

K223105N
K223105O
K223105R

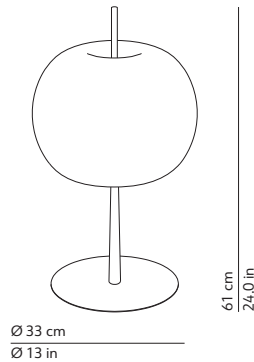

PACKAGING / IMBALLO

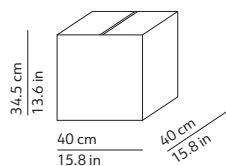

Diffuser
Volume: 0.055 m³ / 1.949 ft³
Gross weight: 3.34 kg / 7.35 lbs

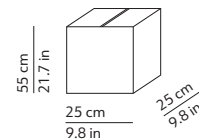

Structure
Volume: 0.016 m³ / 0.552 ft³
Gross weight: 3.93 kg / 8.65 lbs

MATERIALS AND FINISHINGS / MATERIALI E FINITURE

DIFFUSER / DIFFUSORE

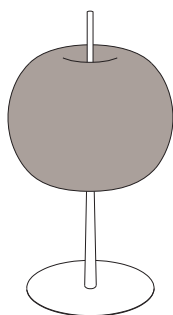

White / Bianco

Two layers of mouth blown glass
Vetro opale incamiciato e soffiato

STRUCTURE / STRUTTURA

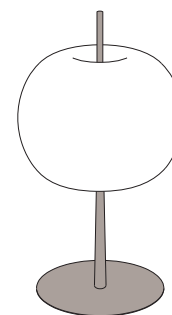

Black / Nero
RAL 9005
Matt / Opaco



Brass / Ottone
Shiny / Lucido



Copper / Rame
Shiny / Lucido

Coated metallic structure
Struttura in metallo verniciato

FURTHER INFORMATION / INFORMAZIONI AGGIUNTIVE

230V
or 120V Feeding / Alimentazione

Light source / Sorgente luminosa
1 x 70W max - E27 (E26)

Energy efficiency class from A++ to E

Dimmer / Varialuce
Yes



Table lamp
Lampada da tavolo



Transparent cord set
EU or UK plug
Cavo di alimentazione trasparente
Spina EU o UK



Transparent electronic loose dimmer 0/100%
Varialuce rompifilo elettronico 0/100% trasparente

ASSEMBLY INSTRUCTIONS
ISTRUZIONI DI MONTAGGIO
INSTRUCCIONES DE MONTAGE
MONTAGE-ANLEITUNG
INSTRUCCIONES DE MONTAJE
ИНСТРУКЦИИ ПО МОНТАЖУ

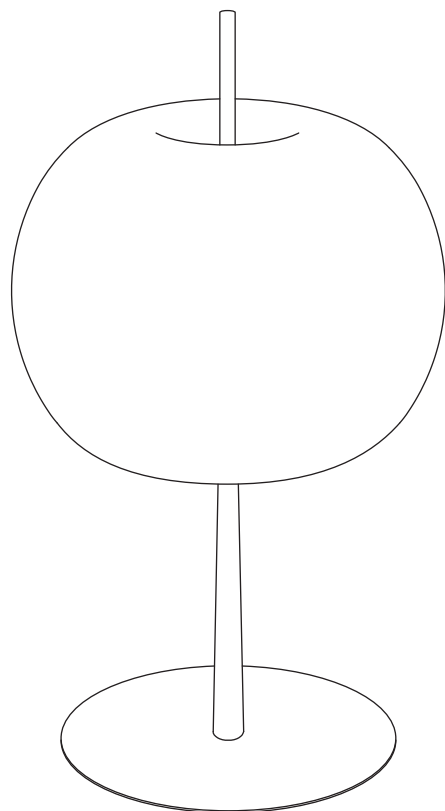

KUSHI XL TABLE

ALBERTO SAGGIA
& VALERIO SOMMELLA

WARNING

The safety is guaranteed by the appropriate use of the following instructions, so you must keep them. Always disconnect the main voltage before working on the appliance. Never use abrasive products or aggressive detergents for cleaning the lamp. If the external cable of this appliance is damaged, it must be replaced by the manufacturer, its after sales service or other equivalent qualified person only in order to avoid any danger. Kundalini will not provide a replacement until the nature of defect has been determined.

ATTENZIONE

La sicurezza dell'apparecchio è garantita con l'uso appropriato delle seguenti istruzioni, pertanto è necessario conservarle. Togliere sempre la tensione prima di operare sull'apparecchio. Per pulire la lampada non usare mai prodotti abrasivi o detersivi aggressivi. Se il cavo esterno di questo apparecchio viene danneggiato, deve essere sostituito esclusivamente dal costruttore, dal suo servizio assistenza, o da personale qualificato equivalente, al fine di evitare pericoli. Kundalini non effettuerà nessuna sostituzione se non dopo aver accertato la natura del difetto.

ATTENTION

La sûreté de l'appareil n'est garantie qu'en suivant scrupuleusement les instructions ci-après. Il est donc nécessaire de les conserver. Isoler l'appareil du secteur avant toute manipulation. Pour nettoyer la lampe, ne jamais utiliser de produits abrasifs ou de nettoyeurs agressifs. Si le câble externe de cet appareil est endommagé, il doit être remplacé uniquement par les soins du constructeur, par son service après-vente ou bien par le personnel équivalent, et ce afin d'éviter tout danger. Kundalini ne remplacera aucun appareil sans en avoir pu vérifier le défaut.

ACHTUNG

Die Sicherheit dieses Artikels wird nur durch die strikte Befolgung der nachfolgenden Betriebsanleitung gewährleistet. Bitte heben Sie diese unbedingt auf. Vor allen Arbeiten ziehen Sie bitte den Stecker aus der Dose. Für die Reinigung der Lampe niemals Schleifmittel oder aggressive Reinigungsmittel verwenden. Sollte das Außenkabel der Lampe beschädigt werden, ist es ausschließlich vom Service-Dienst des Herstellers oder gleichwertigen, qualifiziertem Personal auszutauschen, um somit Gefahren zu vermeiden. Kundalini leistet grundsätzlich erst nach einer gründlichen Überprüfung Ersatz.

ATENCIÓN

La seguridad del aparato está garantizada sólo con el uso apropiado de las instrucciones siguientes, por lo tanto es necesario atenderlas puntualmente. Desconectar siempre la alimentación antes de trabajar en el aparato. Nunca utilice productos abrasivos o detergentes agresivos para limpiar la lámpara. Si el cable externo de este aparato se deteriora será necesario sustituirlo; la sustitución podrá efectuarla exclusivamente el fabricante, su servicio de asistencia o personal cualificado equivalente para evitar peligros. Kundalini no efectuará sustitución alguna hasta después de haber verificado la naturaleza del defecto.

ВНИМАНИЕ!

Безопасность прибора обеспечивается за счет правильного пользования настоящими инструкциями, поэтому необходимо их сохранять. Перед началом работы на приборе всегда отключать напряжение. Для очистки лампы не использовать абразивные продукты или агрессивные чистящие средства. Если внешний кабель прибора поврежден, во избежание опасностей он должен быть заменен только изготовителем, его сервисной службой или равнозначным квалифицированным персоналом. Kundalini не выполняет никаких замен, если не было установлено происхождение дефекта.



IP20



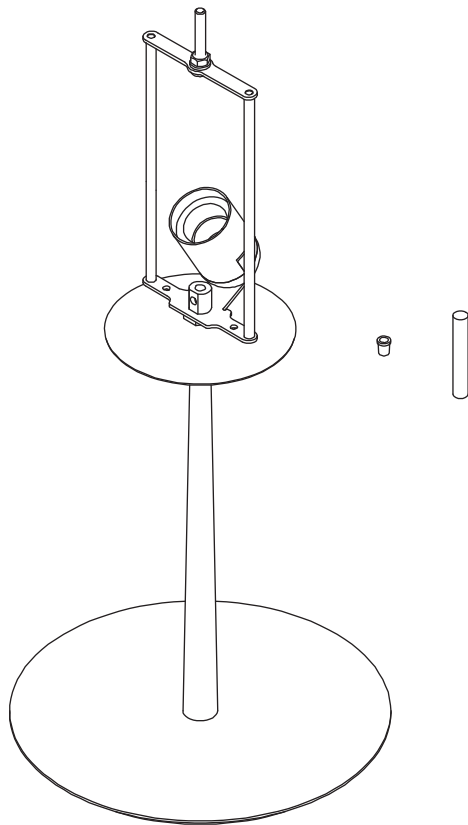

BOX N.1

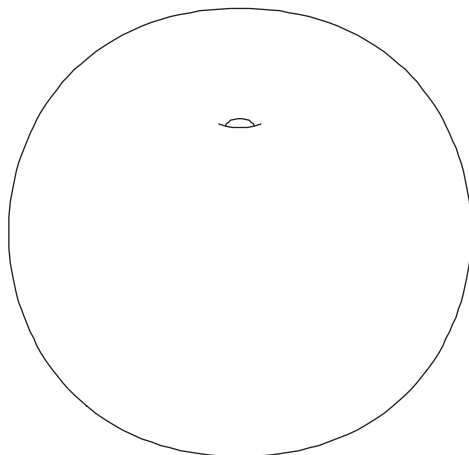

BOX N.2

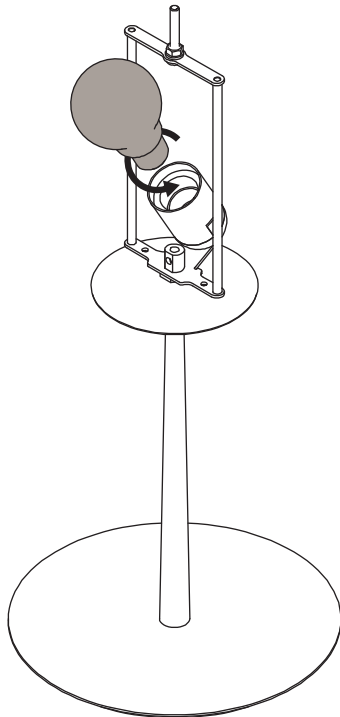
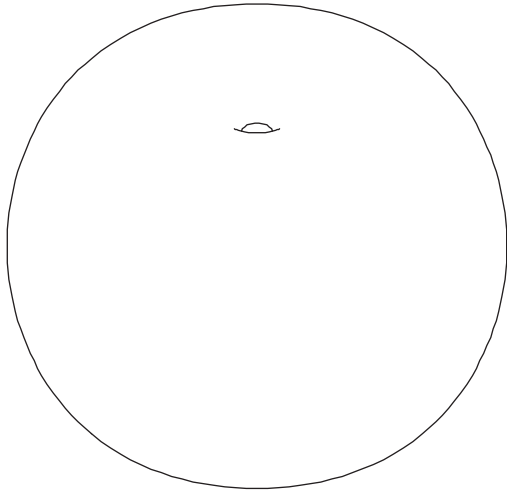

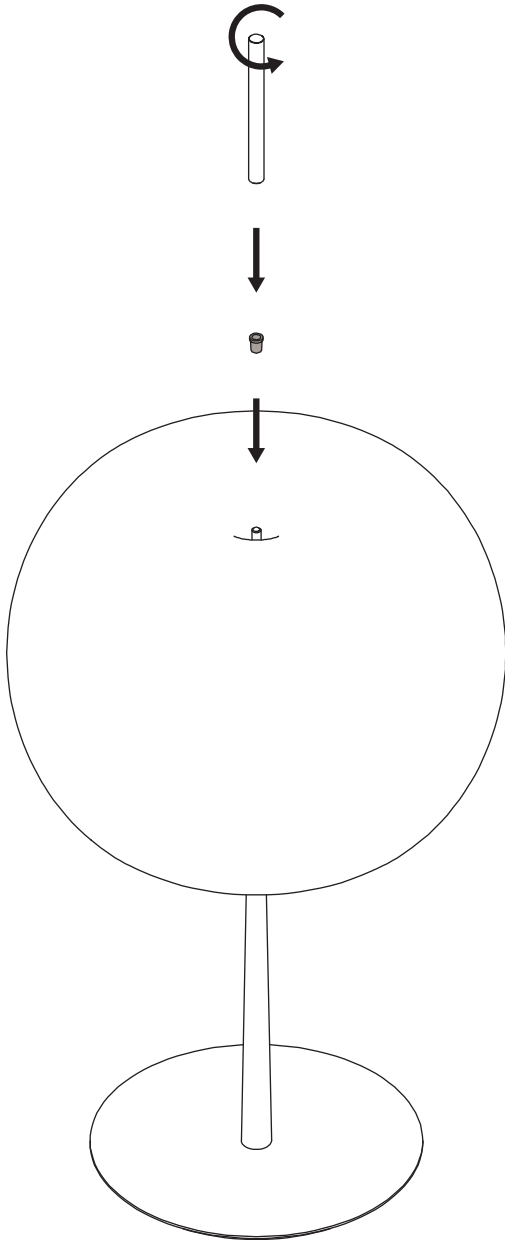

ISTRUZIONI DI MONTAGGIO

Funzionamento del dimmer

Una breve pressione per accendere e spegnere la lampada. Per regolare le luce tenere premuto fino a che non si raggiunge l'intensità desiderata. Regolazione del minimo: da accesa, tenere premuto il tasto di accensione. Dopo 30 secondo la lampada si spegnerà. Alla riaccensione verificare il livello del minimo. Il dimmer supporta tre livelli di minimo. Per cambiare il livello ripetere l'operazione.

ASSEMBLY INSTRUCTIONS

Dimmer

A slight amount of pressure is required to switch the lamp on and off. To adjust the levels, hold down until the desired intensity is reached. Adjustment of the minimum: when switched on, press and hold the power button. After 30 seconds, the lamp will switch off. When it is switched back on, check the minimum level. The dimmer includes three minimum levels. To change the level, repeat the procedure.

INSTRUCTIONS DE MONTAGE

Variateur d'intensité

U ne brève pression pour allumer et éteindre la lampe. Pour ajuster la luminosité, maintenir la pression jusqu'à ce que l'intensité désirée soit atteinte. Réglage du minimum : lorsqu'elle est allumée, maintenir le bouton d'alimentation enfoncé. Après 30 secondes, la lampe s'éteindra. Lors du réallumage, vérifier le niveau minimum. Le variateur d'intensité prend en charge trois niveaux de minimum. Pour changer le niveau, répéter l'opération.

MONTAGE-ANLEITUNG

Dimmer

Kurz Antippen und die Lampe schaltet sich ein und aus. Um das Licht zu regulieren, die Dimmer-Taste gedrückt halten, bis die gewünschte Helligkeit erreicht ist. Einstellung der Mindestleistung: Bei eingeschalteter Lampe die Dimmer-Taste gedrückt halten. Nach 30 Sekunden schaltet sich die Lampe aus. Beim Wiedereinschalten die Mindestleistung prüfen. Der Dimmer unterstützt drei Mindestleistungen. Um die Leistung zu wechseln, den Vorgang wiederholen.

INSTRUCCIONES DE MONTAJE

Regulador

Una breve presión para encender y apagar la lámpara. Para regular las luces tenga presionado hasta que no se alcance la intensidad deseada. Regularización del mínimo: cuando está encendida, mantenga presionada la tecla de encendido. Luego de 30 segundos la lámpara se apagará. Con el nuevo encendido verifique el nivel del mínimo. El regulador admite tres niveles de mínimo. Para cambiar el nivel repita la operación.

ИНСТРУКЦИИ ПО МОНТАЖУ

Работа регулятора света

Выполните кратковременное нажатие для включения и выключения лампы. Чтобы отрегулировать свет, нажмите и удерживайте, пока не будет достигнута требуемая интенсивность. Регулировка минимального уровня: при включенной лампе удерживайте нажатой кнопку включения. Через 30 секунд лампа погаснет. После повторного включения проверьте минимальный уровень. Регулятор света поддерживает три минимальных уровня. - Чтобы изменить уровень, повторите операцию.

BULBS, LAMPADINE, AMPOULES, LEUCHTENMITTEL, BOMBILLAS, ТИП ЛАМПОЧКИ

1x70W - E27 (E26 US)

Energy efficiency class from A++ to E

FEEDING, ALIMENTAZIONE, ALIMENTATION, SPANNUNG, TENSION DE RED, НАПРЯЖЕНИЕ

220-240 / 120 V

