



EN. Suspension lamp with textured and curved glass diffuser. Metallic coated structure.

IT. Lampada a sospensione con diffusore in vetro texturizzato curvato. Struttura in metallo verniciato.

CERTIFICATIONS / CERTIFICAZIONI

Product in class I
Apparecchio di classe I

IP20 Product for indoor use
Apparecchio per uso interno

Product in conformity with the European directive 2006/95/EC
Apparecchio conforme alla direttiva europea 2006/95/EC

Product in conformity with the Eurasian Custom Unions technical regulations
Apparecchio conforme ai regolamenti tecnici dell'Unione doganale Eurasiatica

This lamp must be disposed in conformity with the EU directive 2002/96/EC
Apparecchio di illuminazione da smaltire secondo la direttiva EU 2002/96/EC

CODES AND DIMENSIONS / CODICI E DIMENSIONI

K405340N
K405340

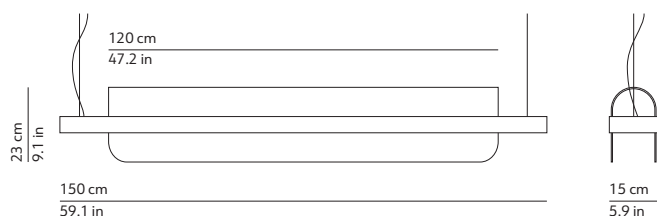

PACKAGING / IMBALLO

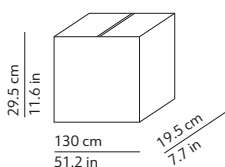

Diffuser
Volume: 0.075 m³ / 2.641 ft³
Gross weight: 7.40 kg / 16.28 lbs

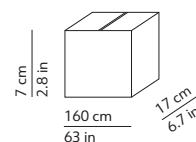

Structure
Volume: 0.019 m³ / 0.672 ft³
Gross weight: 12.60 kg / 27.72 lbs

MATERIALS AND FINISHINGS / MATERIALI E FINITURE

DIFFUSER / DIFFUSORE

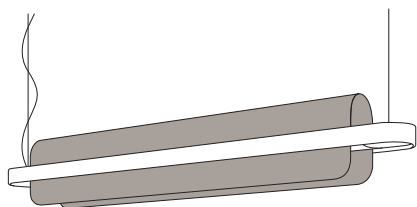

Transparent / Trasparente
 Textured and curved glass
Vetro texturizzato curvato

STRUCTURE / STRUTTURA

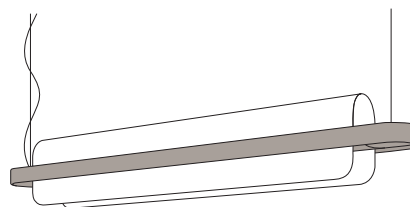

Black / Nero
RAL 9005
Matt / Opaco
 Brass / Ottone
Matt / Opaco
Metallic coated structure
Struttura in metallo verniciato

FURTHER INFORMATION / INFORMAZIONI AGGIUNTIVE

100V or 240V Feeding / Alimentazione

Light source / Sorgente luminosa
4 x 15W - 2700 K - 2520x2 lm - CRI>90 - Board LED

Energy efficiency class A+

Dimmable / Dimmerabile
1-10V

Suspension lamp
Lampada a sospensione

Canopy - L 9.5 in - W 3.2 in - H 2 in - brass
fixed to the ceiling with not provided screws (2-4)
 Rosone - L 24 cm - W 8 cm - H 5 cm - ottone
fissato a soffitto con tasselli (2-4) non forniti

Transparent cord set - length ca. 70.8 in
+ 2 suspension steel wires - length 70.8 in
different lengths on request
Cavo di alimentazione trasparente - lunghezza ca. 180cm
+ 2 cavo di sospensione in acciaio - lunghezza 180cm
altre lunghezze su richiesta

kdl*n*

kundalini.it

ASSEMBLY INSTRUCTIONS
ISTRUZIONI DI MONTAGGIO
INSTRUCCIONES DE MONTAGE
MONTAGE-ANLEITUNG
INSTRUCCIONES DE MONTAJE
ИНСТРУКЦИИ ПО МОНТАЖУ

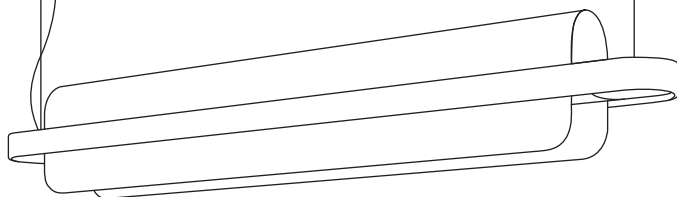

NAMI

ALBERTO SAGGIA
& VALERIO SOMMELLA

WARNING

The safety is guaranteed by the appropriate use of the following instructions, so you must keep them. Always disconnect the main voltage before working on the appliance. Never use abrasive products or aggressive detergents for cleaning the lamp. If the external cable of this appliance is damaged, it must be replaced by the manufacturer, its after sales service or other equivalent qualified person only in order to avoid any danger. Kundalini will not provide a replacement until the nature of defect has been determined.

ATTENZIONE

La sicurezza dell'apparecchio è garantita con l'uso appropriato delle seguenti istruzioni, pertanto è necessario conservarle. Togliere sempre la tensione prima di operare sull'apparecchio. Per pulire la lampada non usare mai prodotti abrasivi o detersivi aggressivi. Se il cavo esterno di questo apparecchio viene danneggiato, deve essere sostituito esclusivamente dal costruttore, dal suo servizio assistenza, o da personale qualificato equivalente, al fine di evitare pericoli. Kundalini non effettuerà nessuna sostituzione se non dopo aver accertato la natura del difetto.

ATTENTION

La sûreté de l'appareil n'est garantie qu'en suivant scrupuleusement les instructions ci-après. Il est donc nécessaire de les conserver. Isoler l'appareil du secteur avant toute manipulation. Pour nettoyer la lampe, ne jamais utiliser de produits abrasifs ou de nettoyeurs agressifs. Si le câble externe de cet appareil est endommagé, il doit être remplacé uniquement par les soins du constructeur, par son service après-vente ou bien par le personnel équivalent, et ce afin d'éviter tout danger. Kundalini ne remplacera aucun appareil sans en avoir pu vérifier le défaut.

ACHTUNG

Die Sicherheit dieses Artikels wird nur durch die strikte Befolgung der nachfolgenden Betriebsanleitung gewährleistet. Bitte heben Sie diese unbedingt auf. Vor allen Arbeiten ziehen Sie bitte den Stecker aus der Dose. Für die Reinigung der Lampe niemals Schleifmittel oder aggressive Reinigungsmittel verwenden. Sollte das Außenkabel der Lampe beschädigt werden, ist es ausschließlich vom Service-Dienst des Herstellers oder gleichwertigen, qualifiziertem Personal auszutauschen, um somit Gefahren zu vermeiden. Kundalini leistet grundsätzlich erst nach einer gründlichen Überprüfung Ersatz.

ATENCIÓN

La seguridad del aparato está garantizada sólo con el uso apropiado de las instrucciones siguientes, por lo tanto es necesario atenderlas puntualmente. Desconectar siempre la alimentación antes de trabajar en el aparato. Nunca utilice productos abrasivos o detergentes agresivos para limpiar la lámpara. Si el cable externo de este aparato se deteriora será necesario sustituirlo; la sustitución podrá efectuarla exclusivamente el fabricante, su servicio de asistencia o personal cualificado equivalente para evitar peligros. Kundalini no efectuará sustitución alguna hasta después de haber verificado la naturaleza del defecto.

ВНИМАНИЕ!

Безопасность прибора обеспечивается за счет правильного пользования настоящими инструкциями, поэтому необходимо их сохранять. Перед началом работы на приборе всегда отключать напряжение. Для очистки лампы не использовать абразивные продукты или агрессивные чистящие средства. Если внешний кабель прибора поврежден, во избежание опасностей он должен быть заменен только изготовителем, его сервисной службой или равнозначным квалифицированным персоналом. Kundalini не выполняет никаких замен, если не было установлено происхождение дефекта.



IP20



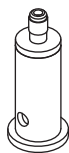
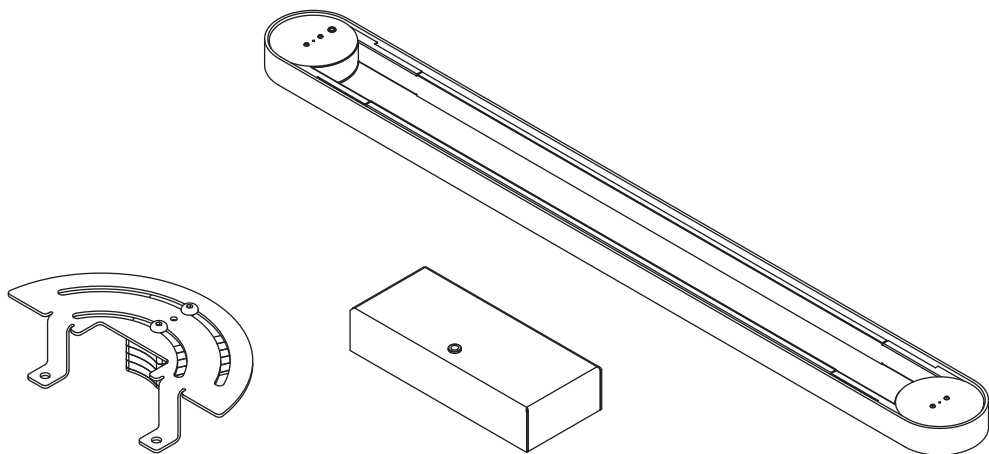

2x



4x



2x

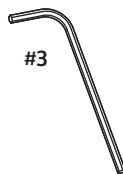

#3

BOX N.1

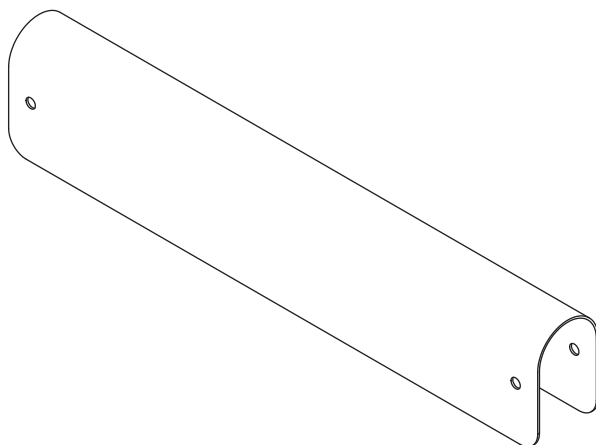

BOX N.2

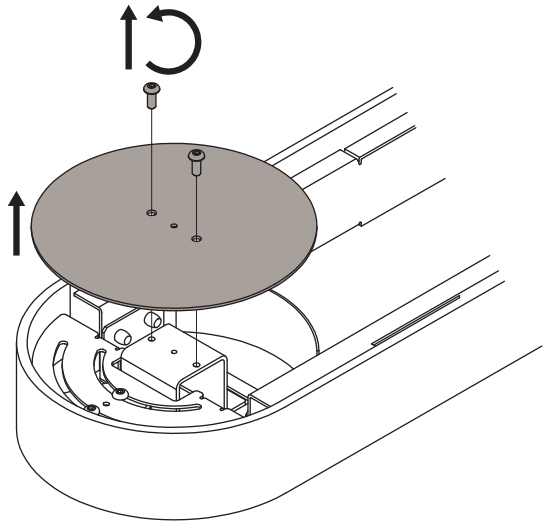
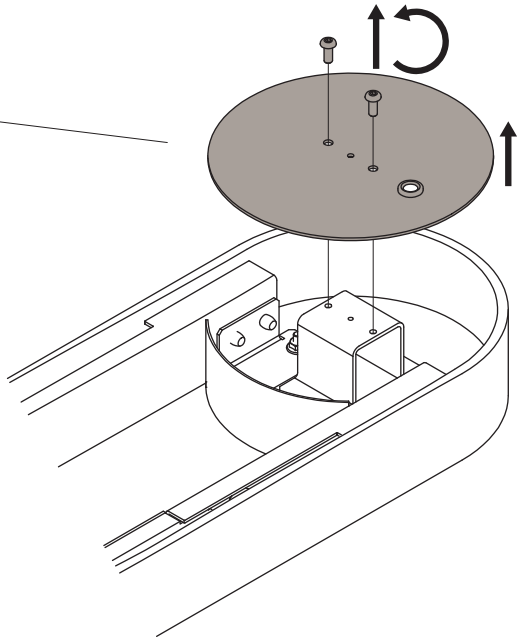
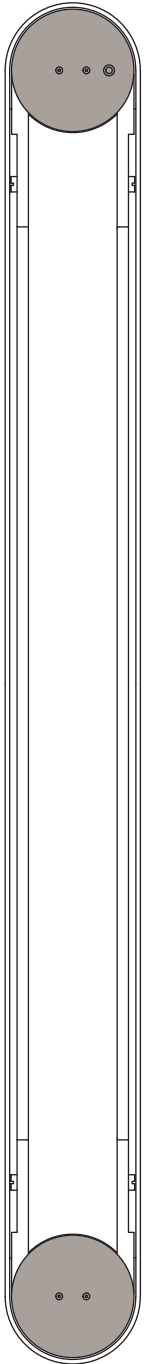

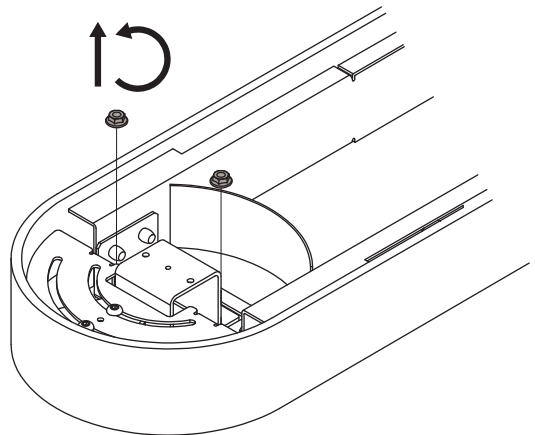
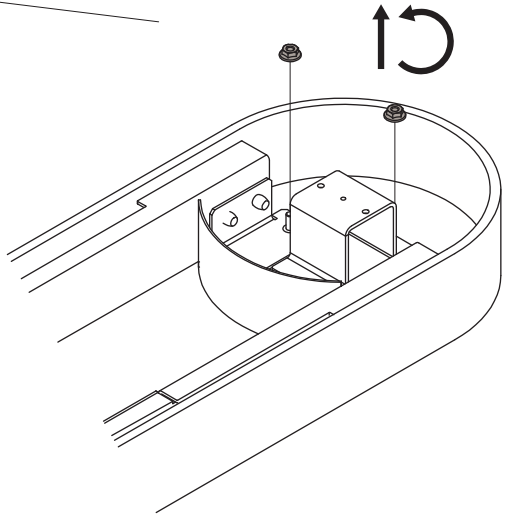
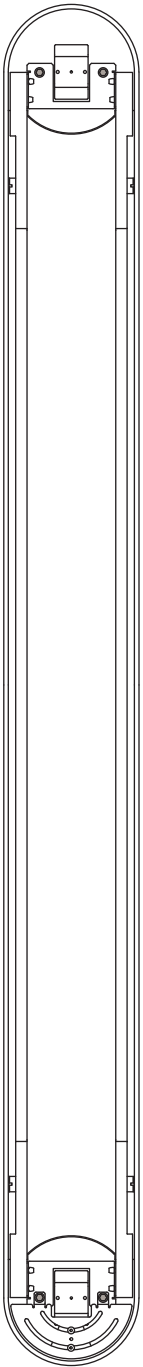

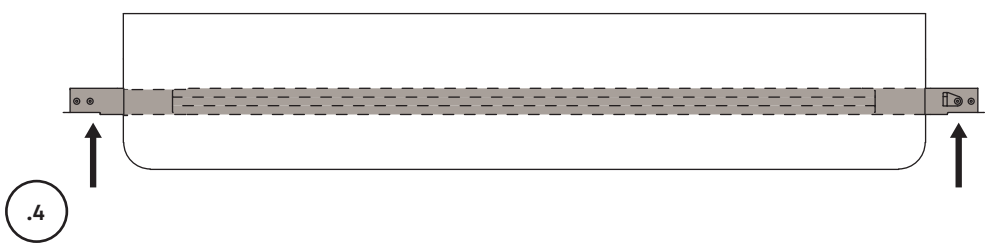
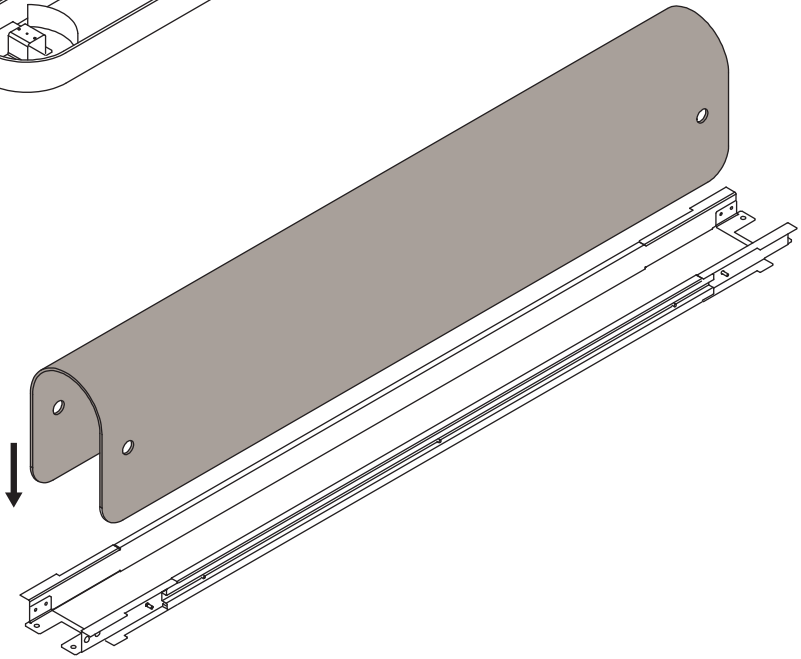
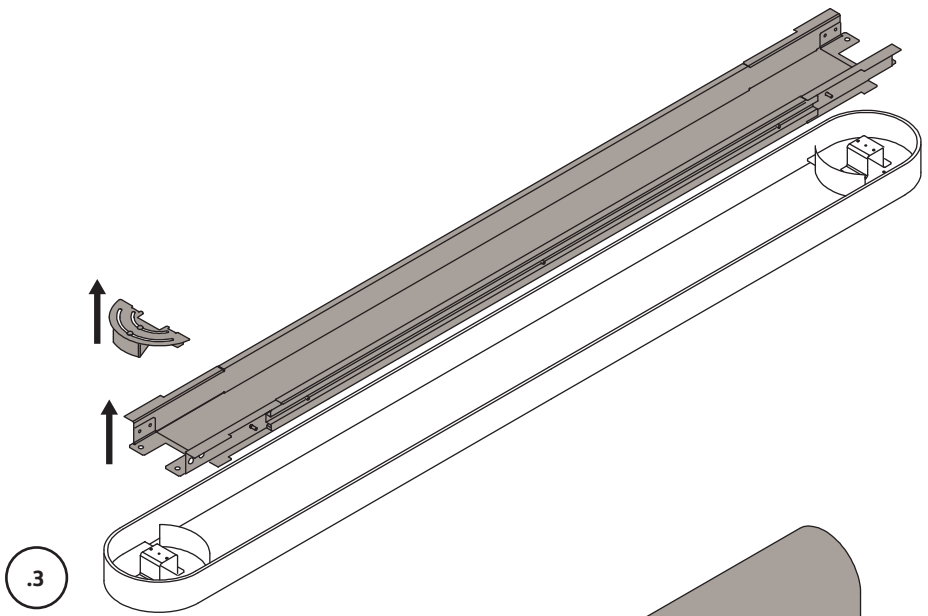

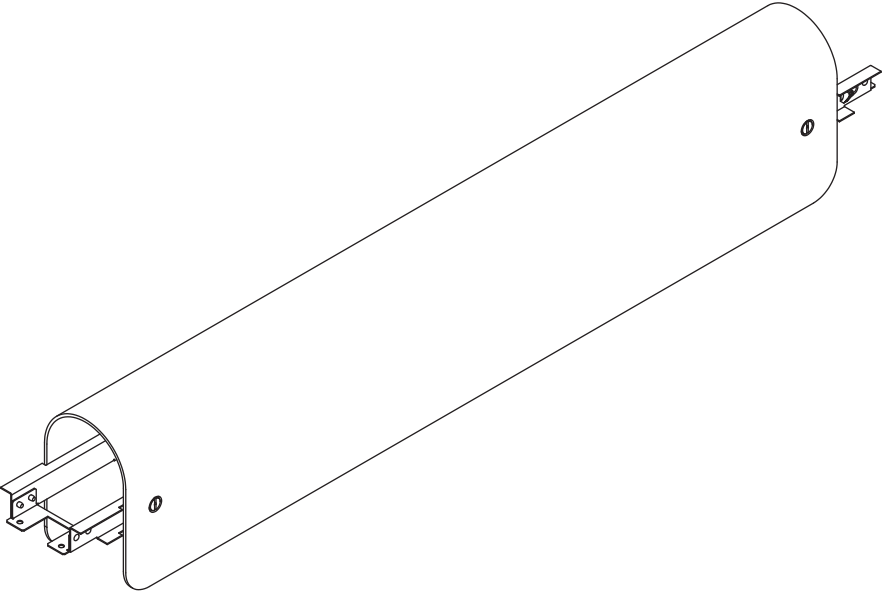
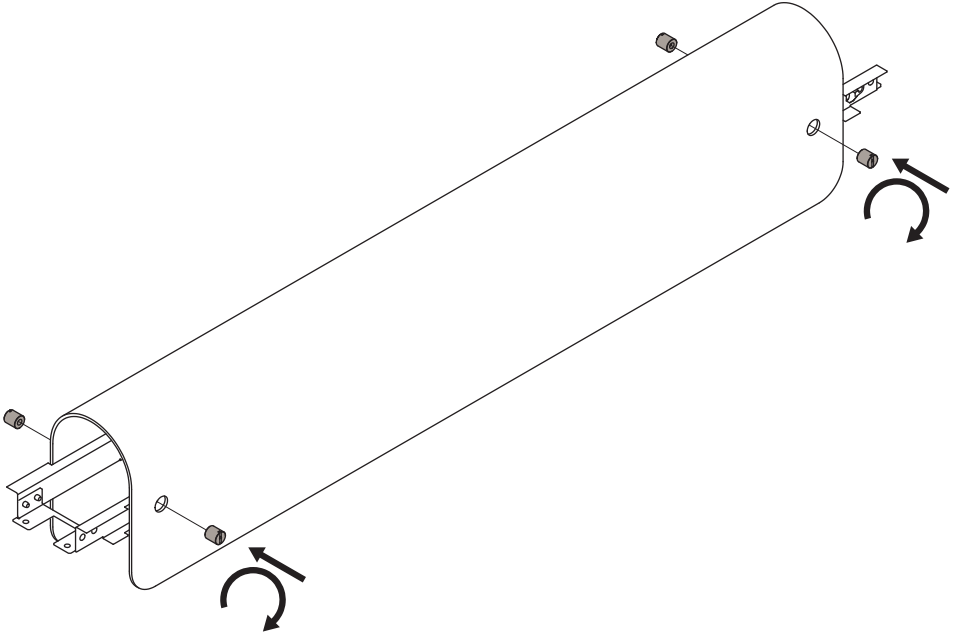

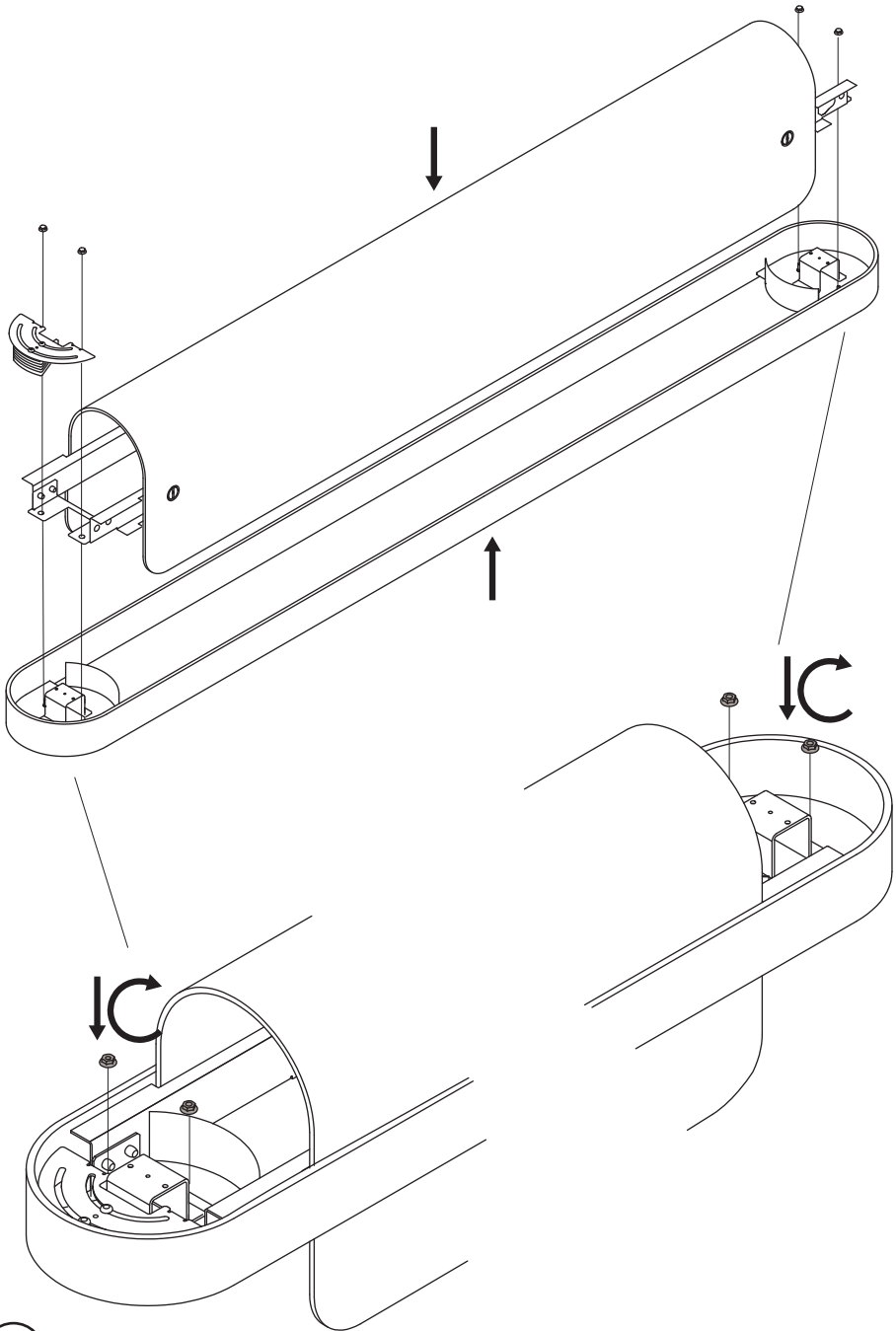

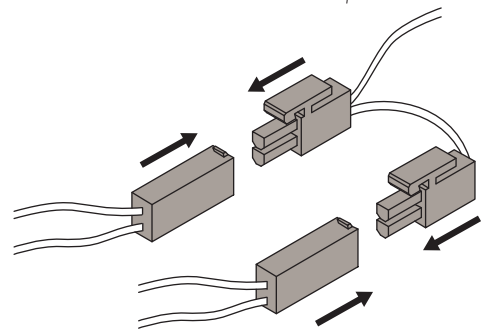
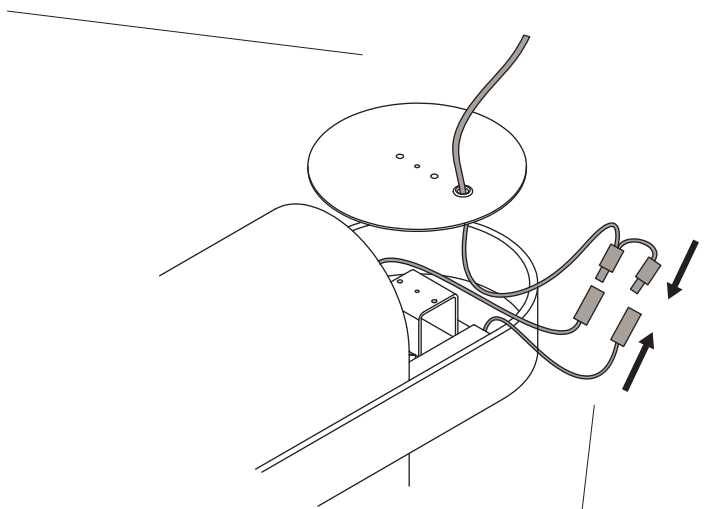
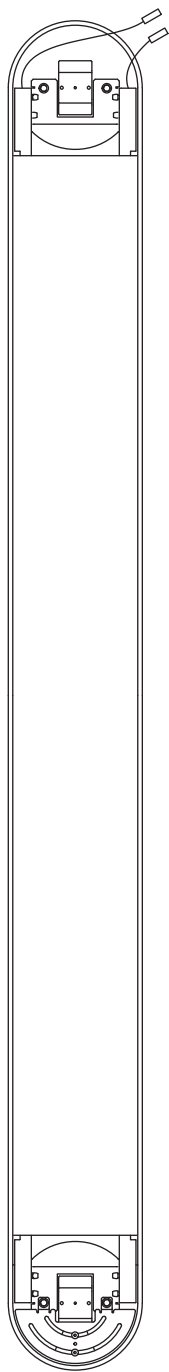

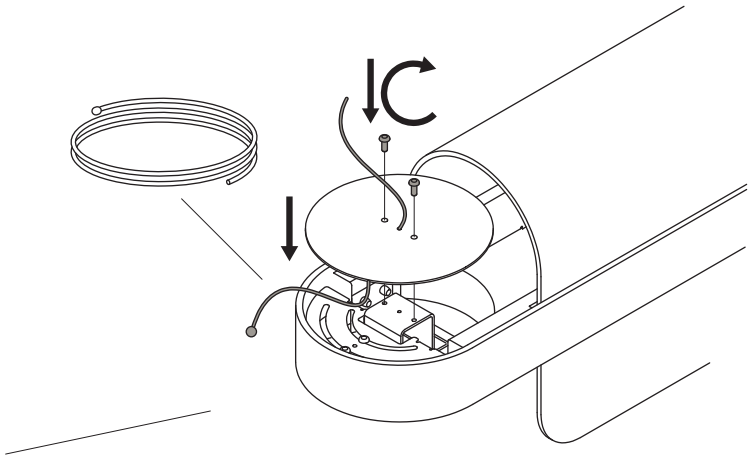
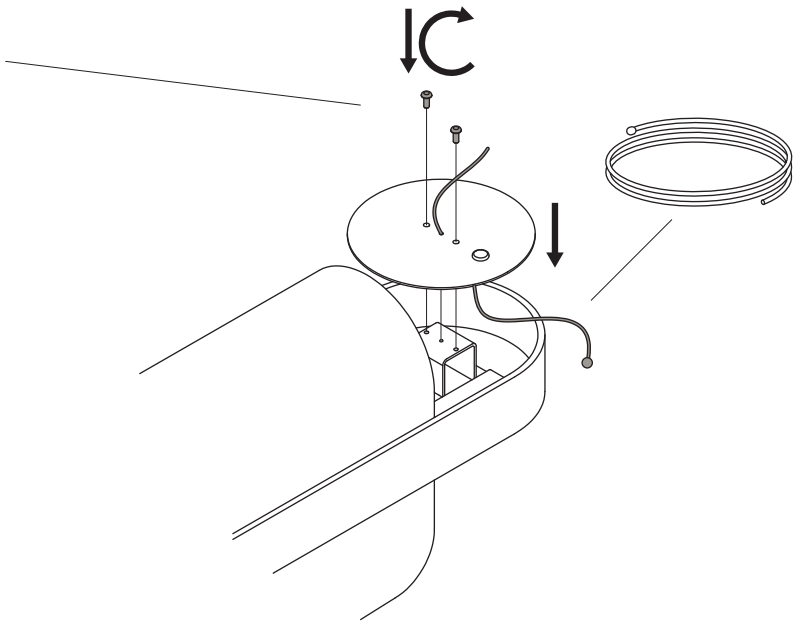
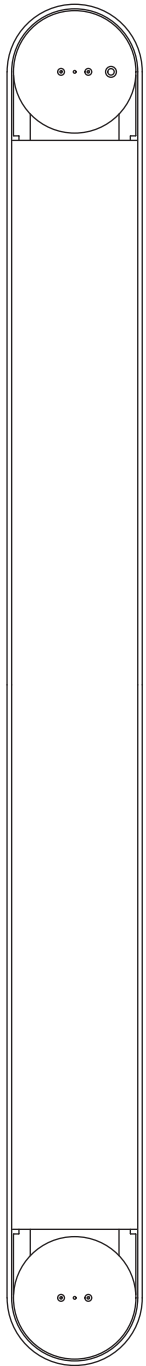

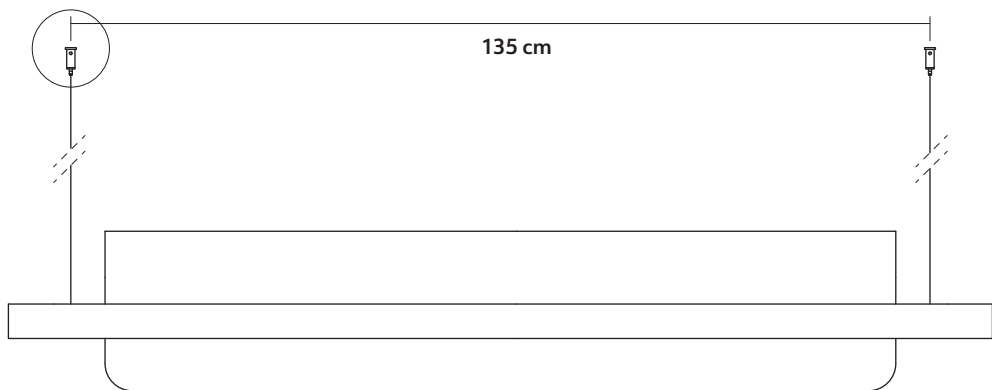
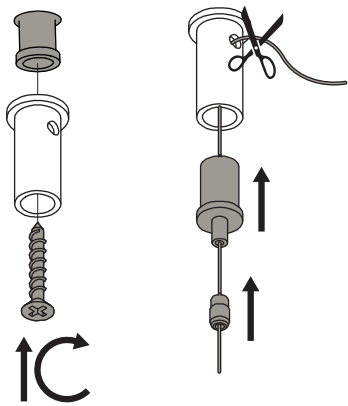

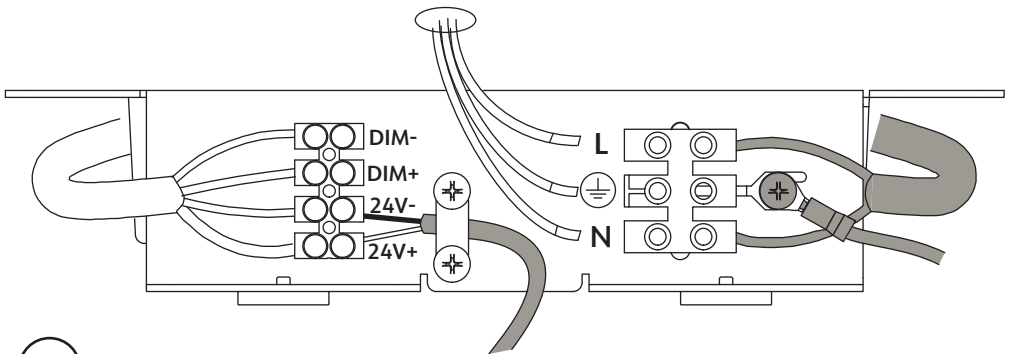
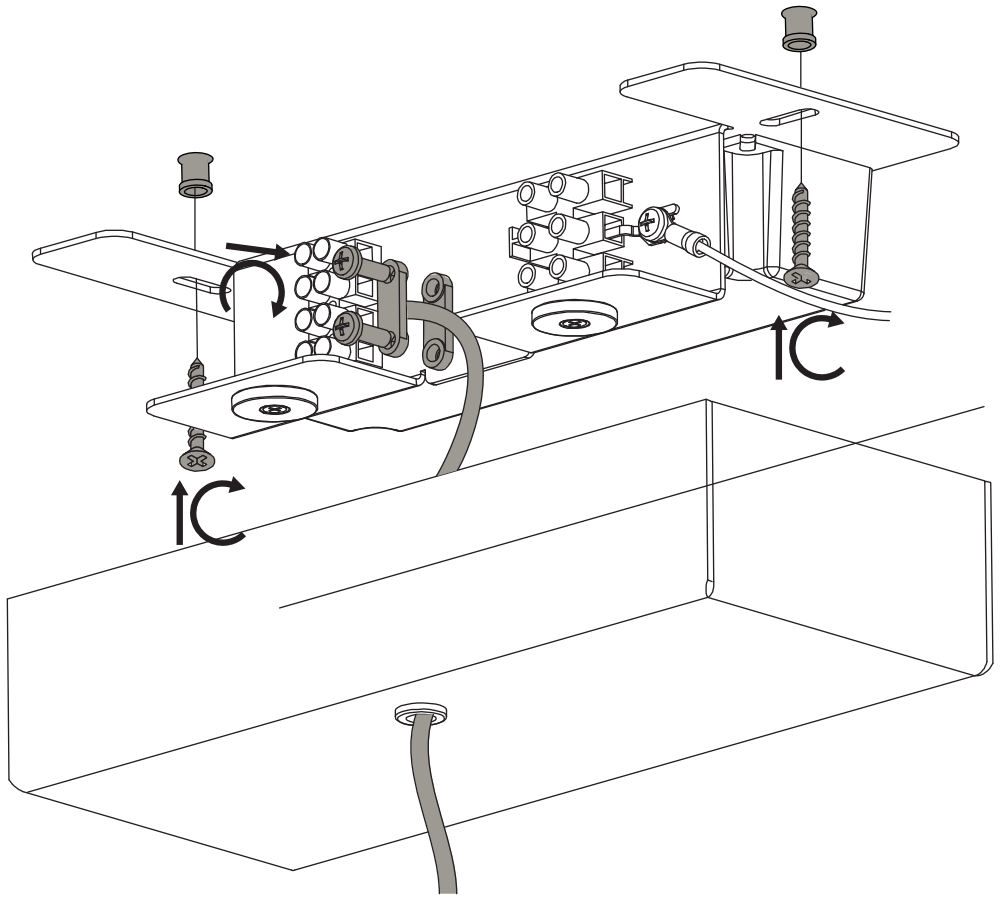

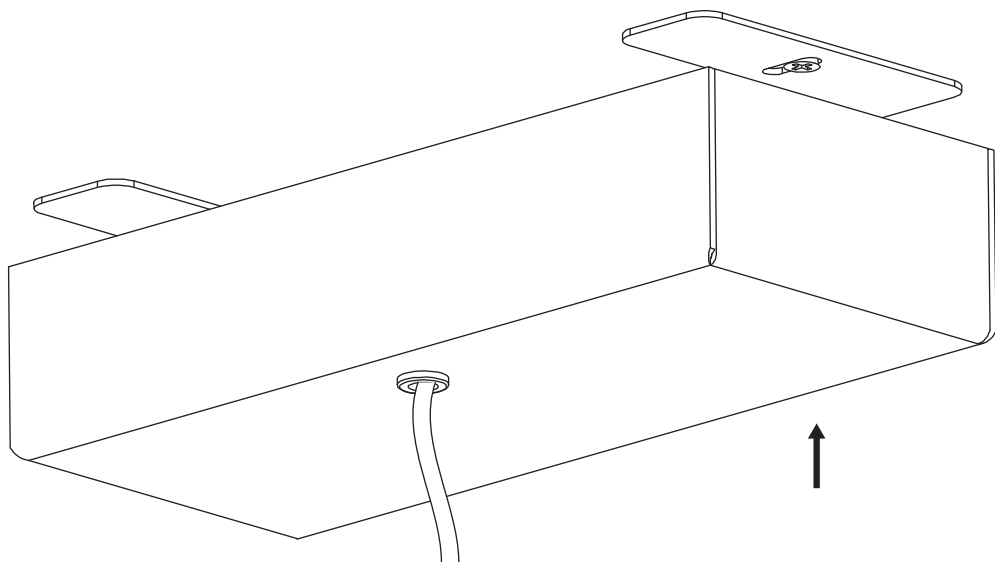

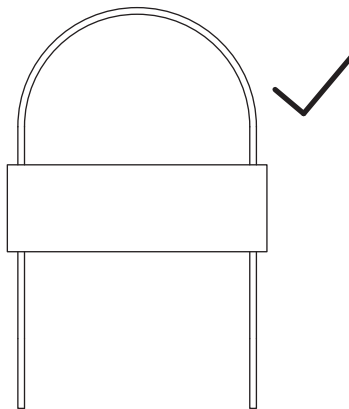
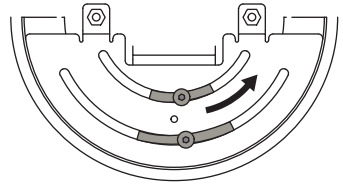
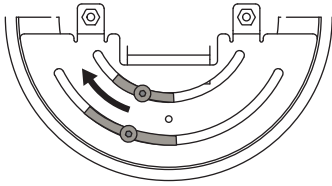
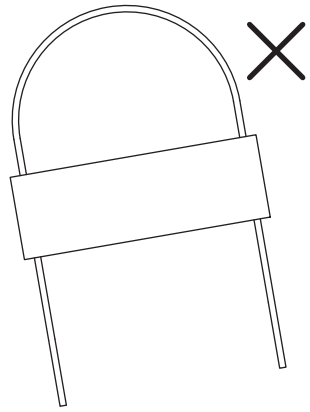
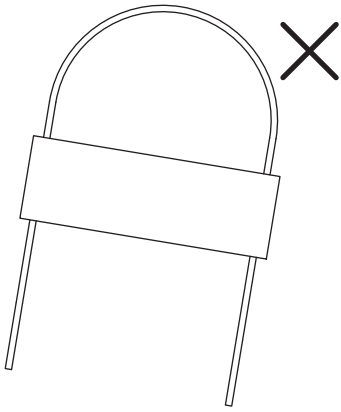

ISTRUZIONI DI MONTAGGIO

Funzionamento del dimmer

Collegare i cavi del dimmer negli ingressi preposti della morsettiera, contrassegnata dall'etichetta "dim + dim -". La lampada accetta esclusivamente segnale dimmer di tipo 1-10V o 10V PWM. Note: impostando il dimmer al minimo la lampada non viene spenta. Per spegnere la lampada inserire un interruttore ON-OFF sul cavo di Linea.

ASSEMBLY INSTRUCTIONS

Dimmer

Connect the dimmer cables to the inputs of the terminal board, labeled with the label "dim + dim -". The lamp only accepts 1-10V or 10V PWM dimmer signal. Note: If the dimmer is set to the minimum, the lamp will not turn off. To turn off the lamp, insert an ON-OFF switch on the line cable.

MONTAGE-ANLEITUNG

Dimmer

Schließen Sie die Dimmerkabel an die Eingänge von Anschluss, an, welche mit dem Verweis „dim + dim -“, gekennzeichnet sind. Die Leuchte akzeptiert nur 1-10V oder 10V PWM Signale. Hinweis: Auch wenn der Dimmer auf das Maximum seiner Leistung geschaltet ist, schaltet sich die Leuchte nicht aus. Um die Leuchte auszuschalten muss ein Ein/Aus Knopf angebracht werden.

INSTRUCTIONS DE MONTAGE

Variateur d'intensité

Connecter les câbles du variateur dans les entrées des bornes, marqué par l'étiquette « dim + dim - ». La lampe accepte uniquement le signal dimmer de type 1-10V ou 10V PWM. Notes: en réglant la luminosité au minimum la lampe ne s'éteint pas. Pour éteindre la lampe insérer un interrupteur marche-arrêt sur la ligne de câble.

INSTRUCCIONES DE MONTAJE

Regulador

Para conectar los cables del dimmer en las entradas del terminal, marcado por la etiqueta "dim + dim -". La lámpara sólo acepta señal dimmer de tipo 1-10V o PWM 10V. Notas: ajustando el dimmer al mínimo la lámpara no se apaga. Para apagar la lámpara insertar un interruptor ON-OFF en el cable de línea.

ИНСТРУКЦИИ ПО МОНТАЖУ

Работа регулятора света

Подсоедините кабели регулятора света к соответствующим входам клеммной колодки, обозначенной этикеткой «dim + dim -». Лампа принимает исключительно сигналы регулятора света типа 1-10 В или 10 В ШИМ. Примечание: при установке регулятора света на минимальный уровень лампа не выключается. Чтобы выключить лампу установите выключатель ВКЛ/ВЫКЛ на линейный кабель.

BULBS, LAMPADINE, AMPOULES, LEUCHTENMITTEL, BOMBILLAS, ТИП ЛАМПОЧКИ

board LED 4 x 15W - 2700K - 2 x 2520lm - CRI>80

Energy efficiency class A+

FEEDING, ALIMENTAZIONE, ALIMENTATION, SPANNUNG, TENSION DE RED, НАПРЯЖЕНИЕ

100-240 V

